

OVERALL DIMENSIONS

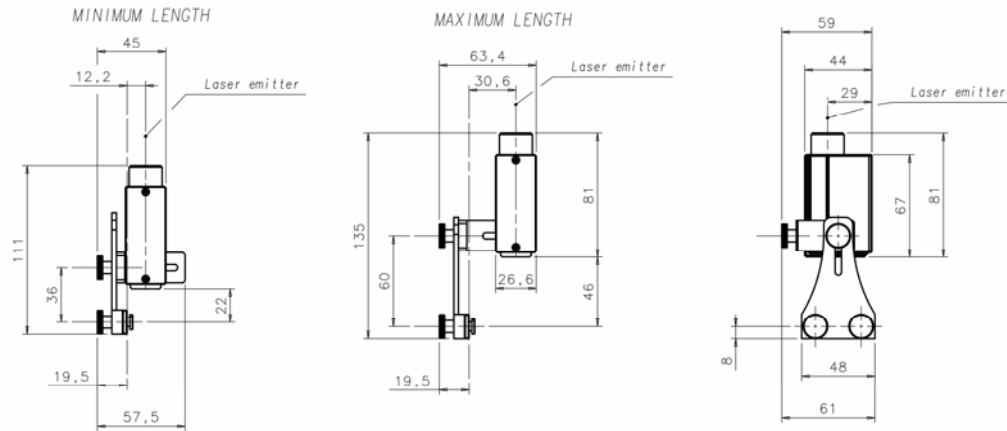

Fig.11

Shows all the overall mechanical dimensions of any possible configuration.

AVAILABLE MODELS

MODEL	DESCRIPTION	ORDER N°
SG-LP	SG-LP Laser pointer	95ASE5590

DECLARATION OF CONFORMITY

DATALOGIC AUTOMATION declare under our sole responsibility that these products are conform to the 2004/108/CE, Directive and successive amendments



WARRANTY

DATALOGIC AUTOMATION warrants its products to be free from defects. DATALOGIC AUTOMATION will repair or replace, free of charge, any product found to be defective during the warranty period of 36 months from the manufacturing date. This warranty does not cover damage or liability deriving from the improper application of DATASENSOR products.

DATALOGIC AUTOMATION Via S. Vitalino 13
40012 Calderara di Reno - Bologna - Italy
Tel: +39 051 3147011 Fax: +39 051 3147453

Operations Office Via Lavino 265
40050 Monte S.Pietro - Bologna - Italy
Tel: +39 051 6765611 Fax: +39 051 6759324

www.automation.datalogic.com e-mail: info.automation@datalogic.com

DATALOGIC AUTOMATION cares for the environment: 100% recycled paper. DATALOGIC AUTOMATION reserves the right to make modifications and improvements without prior notification.

Datalogic and the Datalogic logo are registered trademarks of Datalogic S.p.A. in many countries, including the U.S.A. and the E.U.

SG-LP SERIES Laser pointer

GENERAL INFORMATION

Thanks to its completely new housing and fixing system SG-LP laser pointer can be installed in all safety light curtains profiles of SE, SG2, SG4 and SG Body series. Thanks to a specially designed CAM fixing equipment the laser pointer can be inserted into one of the two lateral grooves either from the top or from the side, depending on which kind of fixing brackets have been used to mount the safety light curtain (standard "L" or TOP-BOTTOM Rotating ones).

One top and one lateral fixing brackets, together with two tightening knobs, allow to adjust SG-LP laser pointer's position in both transversal and longitudinal directions and to have it constantly centred respect light curtain's optical axis, independently from housing width.

HIGHLIGHTS

- To be used to help the mechanical alignment of TX and RX unit of safety light curtain;
- Suitable for all SE, SG2, SG4 and SG Body profiles;
- Installation performed through one of two lateral grooves of the safety light curtain housing;
- Insertion into the groove either from the top or from the side;
- Transversal and longitudinal adjustment, thanks to one top and one lateral fixing brackets, together with two tightening knobs

TYPICAL APPLICATIONS

SG-LP laser pointer is advised to be used to ease TX and RX mechanical alignment process in the following installation conditions:

- Mutli-beam body/access protection safety light curtain whose operating distance is more than 50m;
- Mutli-beam body/access protection safety light curtain installed with deviating mirrors to perform perimetric protections;
- Finger or hand protection safety light curtains installed with deviating mirrors to protect different sides of a machine.

PACKAGE CONTENTS

The package contains the following items:

- | | |
|--|---|
| <ul style="list-style-type: none"> a) Laser pointer (1 pcs) b) Mounting cams ensemble (1 pcs) c) Transversal adjustment bracket (1 pcs) d) Vertical mounting bracket (1 pcs) e) User manual (1 pcs) | <ul style="list-style-type: none"> • Nuts and bolts
4x8 DIN464 Knurled screw (4 pcs) |
|--|---|

SAFETY PRECAUTIONS

NOTE: The SE-SP laser pointer uses a red laser light beam that can be potentially dangerous to the human eye.

Do not stare directly at the light beam.

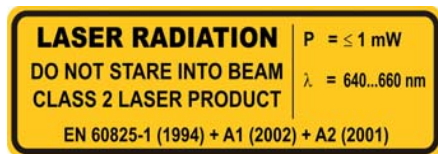

The laser pointer is powered by two 1.5 V AAA type batteries, take care to respect right polarity.

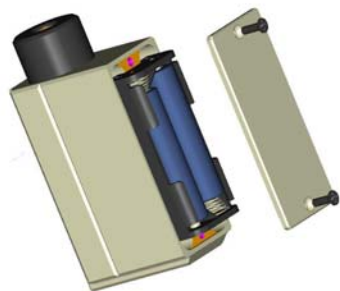

Battery replacement:

With a common cross head screw driver remove the 2 TSP UNI 7688 M2,5x8 screws from bottom closing cap then remove it to have access to the battery box.; put off the battery box, extract the two batteries and replace with new ones. Place the battery box in its place, close with the cap and firmly tighten the screws (Fig. 1).



- Exhausted batteries are designated for separate collection at an appropriate collection point.
- Do not dispose of as household waste.
- For more information, contact the local authorities in charge of waste management.

Fig.1

INSTRUCTIONS

INSTALLATION

- Install the emitting and receiving units of the SE/SG series safety device in the defined positions (refer to MECHANICAL MOUNTING chapter of the safety light curtain instructions manual). The use of floor stands is recommended, verifying that they are firmly fixed and that their axis is perpendicular to the floor.
- SG-LP laser pointer is installed on SG and SE safety light curtains profiles using one of the two lateral grooves. Depending on which kind of fixing bracket is used, laser pointer can be mounted side way or slotted from the top. Side mounting is compulsory when the accessory is installed on SG curtains with TOP-BOTTOM rotating brackets.

TOP MOUNTING

Insert the "b" ensemble inside the lateral groove keeping the couple of cams in vertical position (Fig. 2) until you've reached the right position (Fig. 4).

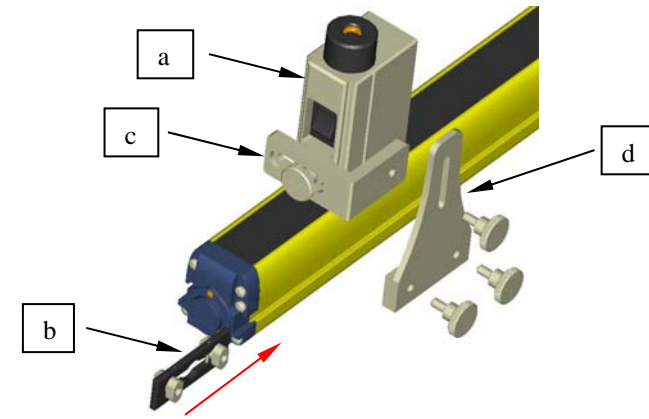

Fig. 2

SIDE MOUNTING

Insert the "b" ensemble abutting on the curtain side corresponding to the lateral groove. Keep the couple of cams in horizontal position (Fig. 3) and after they entered the groove rotate them of 90° (Fig. 4).

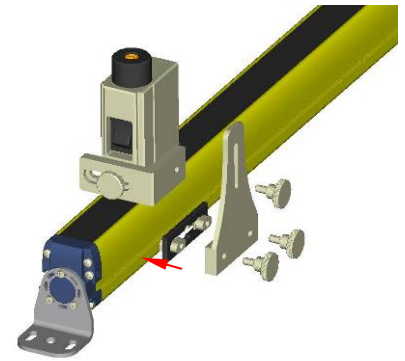

Fig. 3

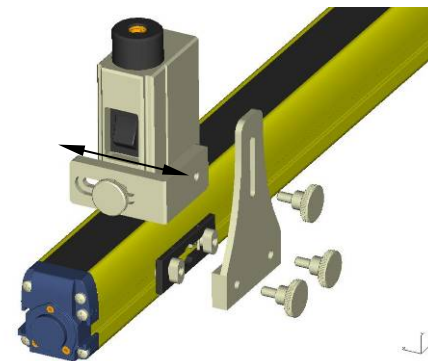

Fig. 4

Bring close the “d” bracket to the “b” ensemble completely and tighten the knurled knobs to firmly fix the system.

Fix the “c” bracket to the “a” ensemble using one of the four knurled knobs, without tightening it completely in order to allow the mutual adjustment between “c” bracket and the laser pointer itself (Fig. 4). As shown in the previous figures it’s sufficient to place such obtained assembly on the light curtain front panel to have a first rough positioning. Bring close, then, the “d” bracket to the “b” ensemble tightening completely the corresponding knurled knobs (Fig. 5).

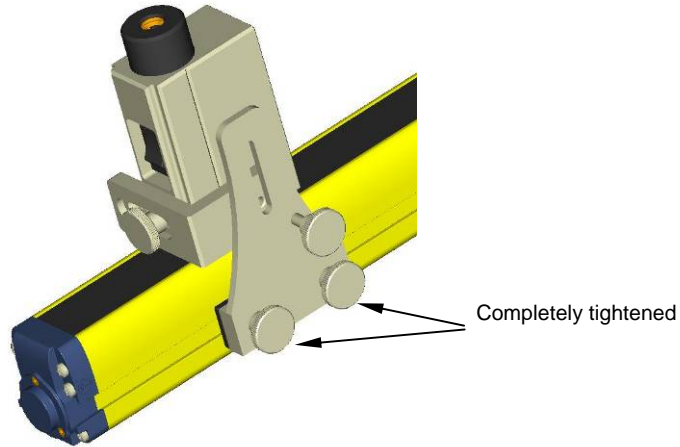

Fig.5

At this point screw last knob fixing together both the “c” and “d” brackets. Tighten the knob firmly keeping the laser pointer group close to the front panel of the curtain (Fig. 6).

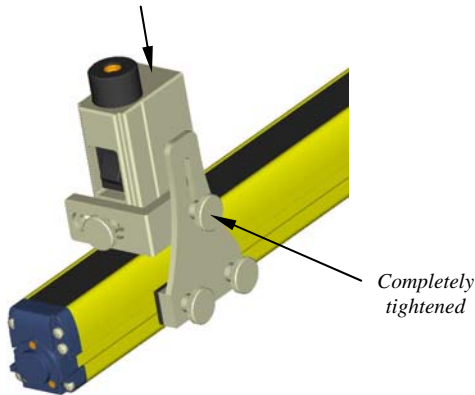

Fig.6

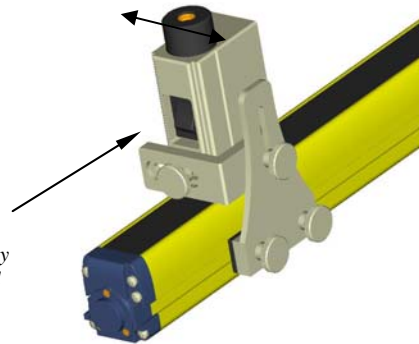

Fig.7

Laser pointer is positioned inside the detection field of the safety device and thus inhibits the functioning during the alignment phase. In case of safety devices for access control, this inconvenience can be avoided by positioning the laser pointer in a zone not affected by optic groups. The device functioning is thus not inhibited and the alignment results can be observed directly on the receiving unit’s signalling LEDs.

ALIGNEMENT

- 1) Power on the laser pointer rotating pushing the dedicated switch. Orientate the emitting unit in order that the laser beam hits the receiving unit at the same height of the pointer.

NOTE: The holes of the fixing bracket or the orientable supports or the rotating brackets, available as accessories, can be used to orientate the unit, allowing angle adjustment along the vertical unit axis. If necessary the inclination of the floor stand can be changed by simply mounting washers under the base.

- 2) Repeat this procedure inserting the pointer in the lower part of the emitting unit; if necessary repeat this procedure unit the desired result is obtained.
- 3) Insert the laser pointer in the upper part of the receiving unit and orient this unit in order that the laser beam hits the emitting unit as indicated.
- 4) Repeat this procedure inserting the laser pointer in the lower part of the receiving unit. After this operation, fix the position of the light curtain remove the laser pointer from controlled area and switch on the safety device and verify the correct alignment. Finally, centre the laser pointer transversal position keeping it close to the front panel, fix defiantly (Fig.7).

NOTE: The laser pointer, due to mechanical tolerance problems in the matching with the light curtain housing, provides an approximate indication and hence small corrections may be necessary in the unit alignment, following the ALIGNMENT PROCEDURE described in the safety light curtain instructions manual.

FIXING

- To disengage the laser pointer is enough to totally unscrew the knobs shown in Fig. 10 and partially the remaining ones.

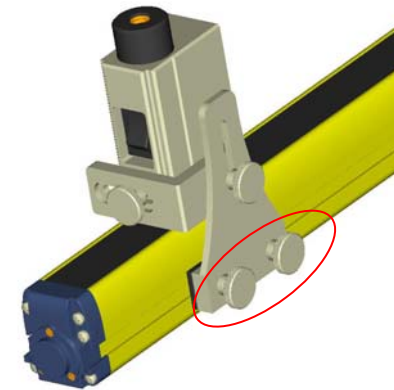

Fig.10

After the aforementioned operation firmly fix the TX and RX units.