

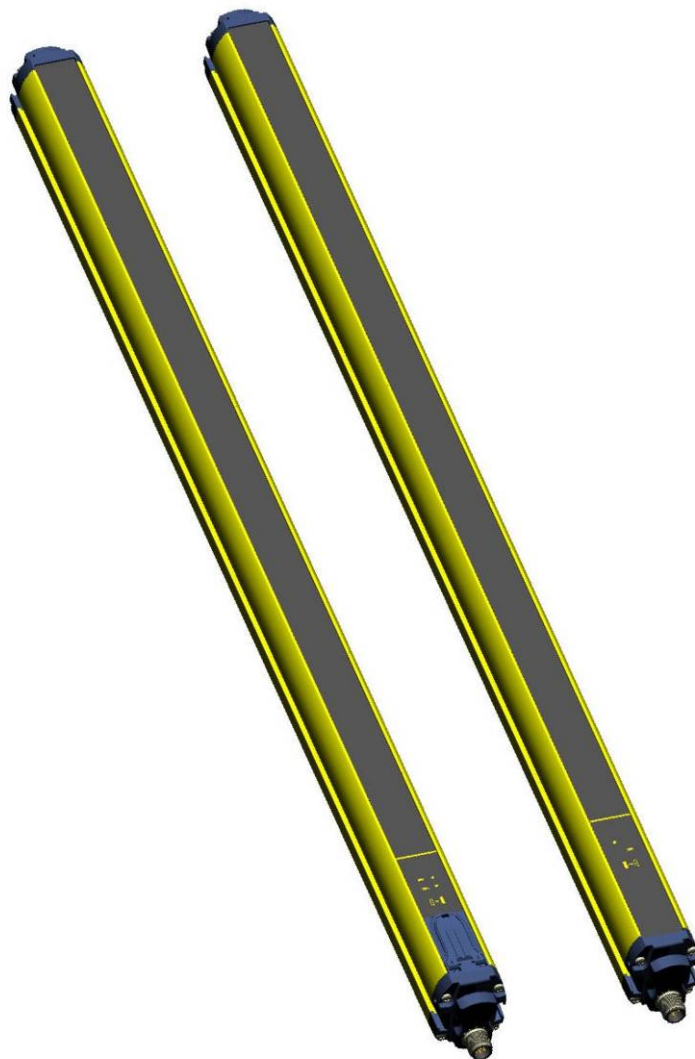

# SG BODY COMPACT SERIES

*base*

Safety light curtains with infrared beams



## INSTRUCTION MANUAL

## ORIGINAL INSTRUCTIONS (ref. 2006/42/EC)

### **DATALOGIC AUTOMATION**

Via Lavino 265 - 40050 Monte S. Pietro - Bologna – Italia

Tel: +39 051 6765611- Fax: +39 051 6759324

[www.automation.datalogic.com](http://www.automation.datalogic.com) e-mail: [info.automation.it@datalogic.com](mailto:info.automation.it@datalogic.com)

DATALOGIC AUTOMATION reserves the right to make modifications and improvements without prior notification.

*Datalogic and the Datalogic logo are registered trademarks of Datalogic S.p.A. in many countries, including the U.S.A. and the E.U.*

**826006500 rev.00** © Copyright Datalogic 2010



Datalogic Automation S.r.l.

Via Lavino 265  
40050 Monte San Pietro  
Bologna - Italy  
[www.automation.datalogic.com](http://www.automation.datalogic.com)

declares that the

**SG2 ; SAFETY LIGHT CURTAINS - ELECTRO-SENSITIVE PROTECTIVE EQUIPMENT  
(TYPE 2 ESPE)**

and all its models

are in conformity with the requirements of the European Council Directives listed below:

**2006 / 42 / EC Machinery Directive  
2004 / 108 / EC EMC Directive  
2006 / 95 / EC Low Voltage Directive**

This Declaration is based upon compliance of the products to the following standards:

EN 61496-1: 2004	SAFETY OF MACHINERY - ELECTRO-SENSITIVE PROTECTIVE EQUIPMENT. PART 1: GENERAL REQUIREMENTS AND TESTS
IEC 61496-2: 2006	SAFETY OF MACHINERY - ELECTRO-SENSITIVE PROTECTIVE EQUIPMENT. PART 2: PARTICULAR REQUIREMENTS FOR EQUIPMENT USING ACTIVE OPTO-ELECTRONIC PROTECTIVE DEVICES (AOPDs)
IEC 61508-1/3/4: 1998	FUNCTIONAL SAFETY OF ELECTRICAL/ELECTRONIC/PROGRAMMABLE ELECTRONIC SAFETY-RELATED SYSTEMS.
IEC 61508-2:2000	SAFETY OF MACHINERY -- SAFETY-RELATED PARTS OF CONTROL SYSTEMS
EN 954-1: 1996	SAFETY OF MACHINERY -- SAFETY-RELATED PARTS OF CONTROL SYSTEMS -- PART 1: GENERAL PRINCIPLES FOR DESIGN
EN ISO 13849-1: 2008	SAFETY OF MACHINERY -- FUNCTIONAL SAFETY OF SAFETY-RELATED ELECTRICAL, ELECTRONIC AND PROGRAMMABLE ELECTRONIC CONTROL SYSTEMS
EN 62061: 2005	ELECTRONIC EQUIPMENT FOR USE IN POWER INSTALLATIONS
EN 50178:1997	ELECTROMAGNETIC COMPATIBILITY (EMC)
EN 61000-6-2: 2005	PART 6-2: GENERIC STANDARDS - IMMUNITY FOR INDUSTRIAL ENVIRONMENTS
EN 55022 (Class A ITE): 2006	LIMITS AND METHODS OF MEASUREMENTS OF RADIO DISTURBANCE OF INFORMATION TECHNOLOGY EQUIPMENT

Conformity has been certified by the following Notified/Competent Body (identification n°0123): TÜV SÜD Rail GmbH, Ridlerstrasse, 65 – D80339 München

Datalogic Automation have a quality system certified by the CSQ, Nr. 9115.IES2, as per ISO 9001 and have therefore observed the regulations foreseen during development and production

Monte San Pietro, April 23th 2010

Paolo Morselli  
Quality Manager



UNI EN ISO 9001

UNI EN ISO 14001



Datalogic Automation S.r.l.

Via Lavino 265  
40050 Monte San Pietro  
Bologna - Italy  
[www.automation.datalogic.com](http://www.automation.datalogic.com)

declares that the

**SG4 ; SAFETY LIGHT CURTAINS - ELECTRO-SENSITIVE PROTECTIVE EQUIPMENT  
(TYPE 4 ESPE)**

and all its models

are in conformity with the requirements of the European Council Directives listed below:

**2006 / 42 / EC Machinery Directive  
2004 / 108 / EC EMC Directive  
2006 / 95 / EC Low Voltage Directive**

This Declaration is based upon compliance of the products to the following standards:

EN 61496-1: 2004	SAFETY OF MACHINERY - ELECTRO-SENSITIVE PROTECTIVE EQUIPMENT. PART 1: GENERAL REQUIREMENTS AND TESTS
IEC 61496-2: 2006	SAFETY OF MACHINERY - ELECTRO-SENSITIVE PROTECTIVE EQUIPMENT. PART 2: PARTICULAR REQUIREMENTS FOR EQUIPMENT USING ACTIVE OPTO-ELECTRONIC PROTECTIVE DEVICES (AOPDs)
IEC 61508-1/3/4: 1998	FUNCTIONAL SAFETY OF ELECTRICAL/ELECTRONIC/PROGRAMMABLE ELECTRONIC SAFETY-RELATED SYSTEMS.
IEC 61508-2:2000	
EN 954-1: 1996	SAFETY OF MACHINERY -- SAFETY-RELATED PARTS OF CONTROL SYSTEMS
EN ISO 13849-1: 2008	SAFETY OF MACHINERY -- SAFETY-RELATED PARTS OF CONTROL SYSTEMS -- PART 1: GENERAL PRINCIPLES FOR DESIGN
EN 62061: 2005	SAFETY OF MACHINERY -- FUNCTIONAL SAFETY OF SAFETY-RELATED ELECTRICAL, ELECTRONIC AND PROGRAMMABLE ELECTRONIC CONTROL SYSTEMS
EN 50178:1997	ELECTRONIC EQUIPMENT FOR USE IN POWER INSTALLATIONS
EN 61000-6-2: 2005	ELECTROMAGNETIC COMPATIBILITY (EMC) PART 6-2: GENERIC STANDARDS - IMMUNITY FOR INDUSTRIAL ENVIRONMENTS
EN 55022 (Class A ITE): 2006	LIMITS AND METHODS OF MEASUREMENTS OF RADIO DISTURBANCE OF INFORMATION TECHNOLOGY EQUIPMENT

Conformity has been certified by the following Notified/Competent Body (identification n°0123): TÜV SÜD Rail GmbH, Ridlerstrasse, 65 – D80339 München

Datalogic Automation have a quality system certified by the CSQ, Nr. 9115.IES2, as per ISO 9001 and have therefore observed the regulations foreseen during development and production

Monte San Pietro, April 23th 2010

Paolo Morselli  
Quality Manager



## INDEX

<b>1. GENERAL INFORMATION</b>	<b>1</b>
1.1. General description of the SAFEasy™ safety light curtain	1
1.2. How to choose the device	2
1.3. Typical applications	3
1.4. Safety information	4
<b>2. INSTALLATION MODE</b>	<b>5</b>
2.1. Precautions to respect for the choice and installation of the device	5
2.2. General information on device positioning	5
2.2.1. Minimum installation distance	5
2.2.2. Minimum distance from reflecting surfaces	6
2.2.3. Installation of several adjacent safety light curtains	8
2.2.4. Use of deviating mirrors	9
2.2.5. Controls after first installation	10
2.2.5. Emitter and receiver orientation	11
<b>3. MECHANICAL MOUNTING</b>	<b>12</b>
<b>4. ELECTRICAL CONNECTIONS</b>	<b>14</b>
4.1. Notes on connections	15
<b>5. ALIGNMENT PROCEDURE</b>	<b>18</b>
5.1. Correct light curtain alignment procedure	18
<b>6. FUNCTIONING MODE</b>	<b>19</b>
6.1. Dip-switch selectable functions	19
6.2. Standard configuration	19
6.3. Restart mode	20
6.4. Test function	22
6.5. Reset function	23
6.6. EDM function	24
<b>7. DIAGNOSTIC FUNCTIONS</b>	<b>25</b>
7.1. Visualisation of the functions	25
7.2. Alignment mode	26
7.3. Operating mode	26
7.4. Fault and diagnostic messages	27
<b>8. CHECKS AND PERIODICAL MAINTENANCE</b>	<b>29</b>
8.1. Maintenance	29
8.2. General information and useful data	30
8.3. Warranty	30
<b>9. TECHNICAL DATA</b>	<b>31</b>
<b>10. LIST OF AVAILABLE MODELS</b>	<b>32</b>
<b>11. DIMENSIONS</b>	<b>33</b>
<b>12. ACCESSORIES</b>	<b>34</b>
12.1. Fixing brackets	34
12.2. Rotating brackets	36
12.3. Deviating mirror	37
12.4. Column and floor stand	38
12.5. Protective stands SE Series	39
12.6. Protective stands SG Series	40
12.7. Connection cables	41
12.8. SE-SR2 Safety relay	41
12.9. Test piece	42
12.10. Laser pointer	43
<b>14. GLOSSARY</b>	<b>44</b>

## 1. GENERAL INFORMATION

### 1.1. General description of the SAFEasy™ safety light curtain

The SAFEasy™ safety light curtains of the SG BODY COMPACT series, are optoelectronic multibeam devices that can be used to protect working area that, in presence of machines, robots, and automatic systems in general, can become dangerous for operators that get in touch, even accidentally, with moving parts.

The SAFEasy™ light curtains of the SG BODY COMPACT series are Type 4 intrinsic safety systems used as accident-prevention protection devices and are manufactured in accordance with the international Standards in force for safety, in particular:

**CEI EN 61496-1:** 2004 Safety of machinery: electro-sensitive protective equipment. Part 1: General requirements and tests.

**CEI IEC 61496-2:** 2006 Safety of machinery: electro-sensitive protective equipment. Particular requirements for equipment using active optoelectronic protective devices.

The device, consisting in one emitting and one receiving units housed inside strong aluminium profiles, generates infrared beams that detect any opaque object positioned within the light curtain detection field.

The emitting and the receiving units are equipped with the command and control functions. The connections are made through a M12 connector located in the lower side of the profile.

The synchronisation between the emitter and the receiver takes place optically, i.e. no electrical connection between the two units is required.

The microprocessors guarantee the check and the management of the beams that are sent and received through the units: the microprocessors – through some LEDs – inform the operator about the general conditions of the light curtain and about eventual faults (see section 7 “Diagnostic functions”). During installation, two yellow LEDs facilitate the alignment of both units (see section 5 “Alignment procedures”).

As soon as an object, a limb or the operator’s body accidentally interrupts the beams sent by the emitter, the receiver immediately opens the OSSD output and blocks the machine (if correctly connected to the OSSD).

**Note:** The following abbreviations, defined by the standards in force, will be used in this manual:

**AOPD** Active opto-electronic protective device  
**ESPE** Electro-sensible protective equipment  
**OSSD** Output signal switching device (switching output)  
**TX** Emitting device  
**RX** Receiving device  
**EDM** External device monitoring

Some parts or sections of this manual containing important information for the operator are preceded by a note:



Notes and detailed descriptions about particular characteristics of the SAFEasy™ safety devices in order to better explain their functioning; special instructions regarding the installation process.

The information provided in the paragraphs following this symbol is very important for safety and may prevent accidents.



Always read this information accurately and carefully follow the advice to the letter.

This manual contains all the information necessary for the selection and operation of the SAFEasy™ safety devices.

However, specialised knowledge not included in this technical description is required for the planning and implementation of a safety light curtain on a power-driven machine.

As the required knowledge may not be completely included in this manual, we suggest the customer to contact DATALOGIC AUTOMATION Sales Technical Service for any necessary information relative to the functioning of the SG BODY COMPACT series light curtains and the safety rules that regulate the correct installation (see section 8 “Checks and periodical maintenance”).

1.2. How to choose the device

 There are at least three different main characteristics that should be considered when choosing a safety light curtain:

- **The resolution** strictly depending on the part of the body to be protected.  
 The resolution of the device is the minimum dimension, which an opaque object must have in order to obscure at least one of the beams that constitute the sensitive area.  
 As shown in Fig.1, the resolution only depends on the geometrical characteristics of the lenses, diameter and distance between centres, and is independent of any environmental and operating conditions of the safety light curtain.  
 The resolution value is obtained applying the following formula:

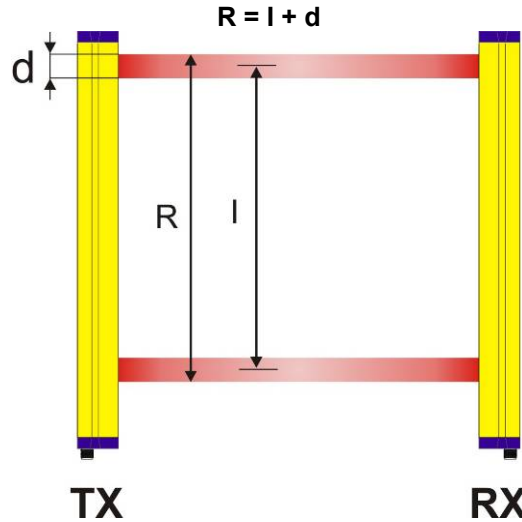

Fig. 1

The following table shows the values of the optic interaxis (I), the resolution (R) and the optic diameter (d), of the safety light curtains.

Model	Optic interaxis mm (I)	N°. optics (n)	Resolution mm (R)	Optics Ø mm (d)	Operating distance m
SG2-S2-050-PP-E	500	2	515	15	0.5..50
SG2-S3-080-PP-E	400	3	415	15	0.5..50
SG2-S4-090-PP-E	300	4	315	15	0.5..50
SG2-S4-120-PP-E	400	4	415	15	0.5..50
SG4-S2-050-PP-E	500	2	515	15	0.5..50
SG4-S3-080-PP-E	400	3	415	15	0.5..50
SG4-S4-090-PP-E	300	4	315	15	0.5..50
SG4-S4-120-PP-E	400	4	415	15	0.5..50

**Note:** Safety light curtains for body protection with sensitive area heights and optic interaxis different from the standard versions can be manufactured upon specific request.

### • The height of the protected area

It is important to distinguish between “Height of the sensitive area” and “Height of the controlled area” (see Fig.2).

- The height of the sensitive area is the distance between the lower and the upper limits respectively of the first and the last lens.
- The height of the controlled area is the effectively protected area; it delimits the area where an opaque object with larger or equal dimensions respect to the resolution of the safety light curtain may certainly cause the interruption of a beam.

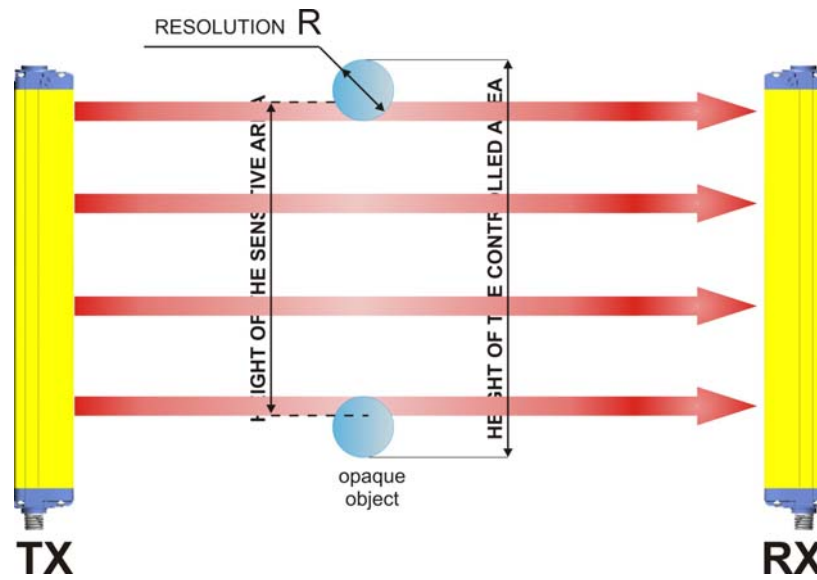

Fig. 2

### • The safety distance

It is important to carefully calculate the distance between the point where the safety device will be placed and the possible danger associated with the machine to be protected (see section 2 “*Installation mode*” for the calculation of the safety distance).

### 1.3. Typical applications

The **SAFEasy™** safety light curtains of the SG BODY COMPACT series are used in all automation fields where control and protection of the access to dangerous zones is necessary.

In particular they are used to stop the moving mechanical parts in:

- Palletisers / depalletisers;
- Packaging machines, handling machines, storing machines;
- Automatic and semi-automatic assembly lines;
- Automatic warehouses;
- Robotics.



In food industry applications, DATALOGIC AUTOMATION Technical Service has to verify the compatibility of the material of the safety light curtain housing with any chemical agents used in the production process.

#### 1.4. Safety information



The following points must be observed for a correct and safe use of the **SAFEasy™** safety light curtains of the SG BODY COMPACT series:

- The stopping system of the machine must be electrically controlled.
- This control system must be able to instantly stop the dangerous movement of the machine during all the phases of the working cycle.
- Mounting and connection of the safety light curtain must only be carried-out by qualified personnel, according to the indications included in the special sections (refer to sections 2; 3; 4; 5; 6).
- The safety light curtain must be securely placed in a particular position so that access to the danger zone is not possible without the interruption of the beams (see section 2 "*Installation mode*").
- The personnel operating in the dangerous area must be well trained and must have adequate knowledge of all the operating procedures of the safety light curtain.
- The TEST/START button must be located outside the protected area because the operator must check the protected area during all the Test and Reset operations.
- The function of the external device monitoring (EDM) is active only if the specific wire is correctly connected to the device. Please carefully read the instructions for the correct functioning before powering the light curtain.

## 2. INSTALLATION MODE

### 2.1. Precautions to respect for the choice and installation of the device



- Make sure that the protection level assured by the **SAFEasy™** (Type 4 or Type 2) is compatible with the real danger level of the machine to be controlled, according to ISO EN 13849-1.
- The outputs (OSSD) of the ESPE must be used as machine stopping devices and not as command devices.  
The machine must have its own START command.
- The dimension of the smallest object to be detected must be larger than the resolution level of the ESPE.
- The ESPE must be installed respecting the technical characteristics indicated in section 9.
- Do not place the device, in particular the receiving unit, near intense light sources.
- Strong electromagnetic interferences can compromise the correct functioning of the device. DATALOGIC AUTOMATION suggests contacting its own Technical Service when this problem occurs.
- The operating distance of the device can be reduced by 50% in the presence of smog, fog or airborne dust.
- A sudden change in environment temperature, with very low minimum peaks, can generate a small condensation layer on the lenses and so jeopardise functioning.

### 2.2. General information on device positioning

#### 2.2.1. Minimum installation distance

The safety device must be placed at a specific safety distance (Fig.3). This distance must ensure that the danger zone cannot be reached before the dangerous motion of the machine has been stopped by the ESPE.

The safety distance depends on 4 factors, according to the EN-999, 775 and 294 Standards:

- 1 Response time of the ESPE (the time between the effective beam interruption and the opening of the OSSD contacts).
- 2 Machine stopping time (the time between the effective opening of the contacts of the ESPE and the real stop of the dangerous movement of the machine).
- 3 ESPE resolution.
- 4 Approaching speed of the object to be detected.

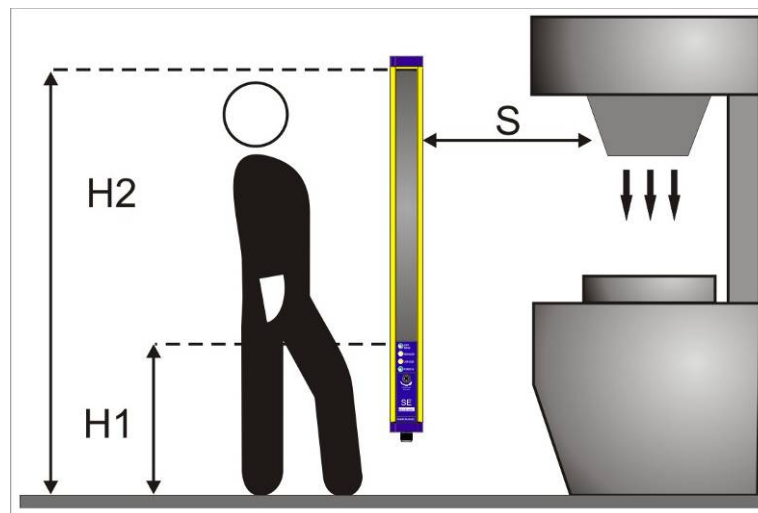

Fig. 3

The following formula is used for the calculation of the safety distance:

$$S = K (t_1 + t_2) + C$$

where:

- S** = Minimum safety distance in mm.
- K** = Speed of the object, limb or body approaching the dangerous area in mm/sec.
- t<sub>1</sub>** = Response time of the ESPE in seconds (see section 9 "Technical data")
- t<sub>2</sub>** = Machine stopping time in seconds.
- d** = Resolution of the system.
- C** = 850 mm for device with resolution > 40mm.

**Note:** The value of K is:

- 2000 mm/s if the calculated value of S is ≤ 500 mm**
- 1600 mm/s if the calculated value of S is > 500 mm**

When devices with >40 mm resolution are used, the height of the top beam has to be ≥ 900 mm (H2) while the height of the bottom beam has to be ≤ 300 mm (H1).

**2.2.2. Minimum distance from reflecting surfaces**

Reflecting surfaces placed near the light beams of the **SAFEasy™** device (over, under or laterally) can cause passive reflections. These reflections can compromise the recognition of an object inside the controlled area (see Fig.4).

However, if the **RX** receiver detects a secondary beam (reflected by the side-reflecting surface) the object might not be detected, even if the object interrupts the main beam.

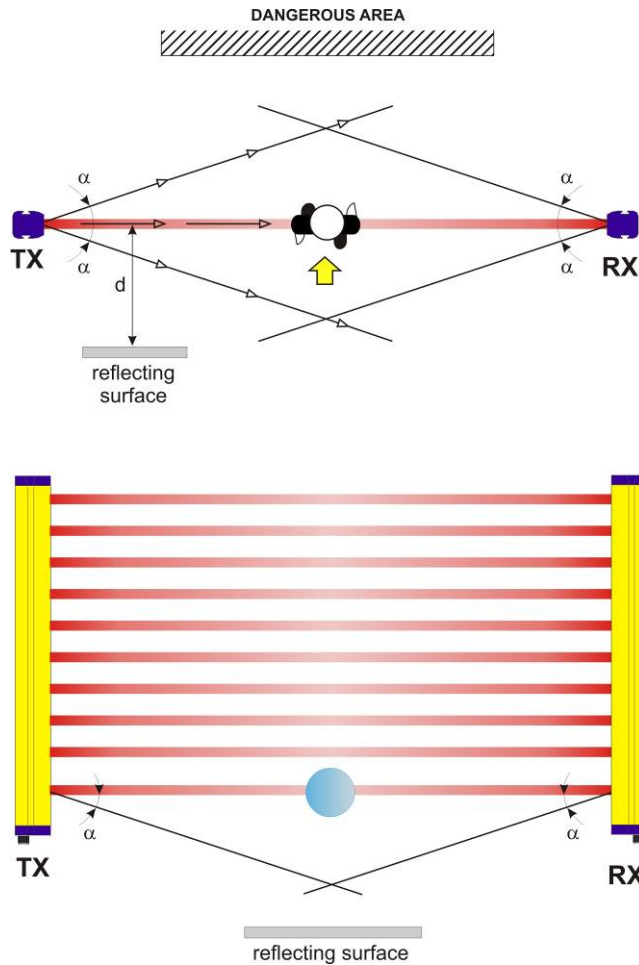

Fig. 4

It is thus important to position the safety light curtain according to the minimum distance from reflecting surfaces. The minimum distance depends on:

- Operating distance between emitter (TX) and receiver (RX);
- Maximum aperture angle of the light beam emitted by the safety light curtain, depending on the type of the device; in particular:
  - 5° for ESPE type 4 (± 2.5° as to the optic axis)
  - 10° for ESPE type 2 (± 5° as to the optic axis)

**Type 4 ESPE**

Diagram in the following figure shows the minimum distance from the reflecting surface ( $D_{sr}$ ), based on the operating distance for a Type 4 ESPE:

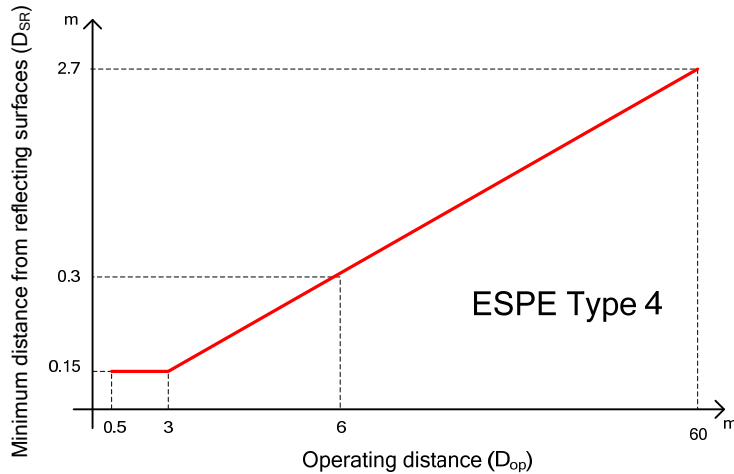

The formula to get  $D_{sr}$  for a Type 4 ESPE is the following:

$$D_{sr} (m) = 0.15 \quad \text{for operating distance} < 3 \text{ m}$$

$$D_{sr} (m) = 0.5 \times \text{operating distance (m)} \times \text{tg } 2\alpha \quad \text{for operating distance} \geq 3 \text{ m}$$

**Type 2 ESPE 2**

Diagram in the following figure shows the minimum distance from the reflecting surface ( $D_{sr}$ ), based on the operating distance for a Type 2 ESPE:

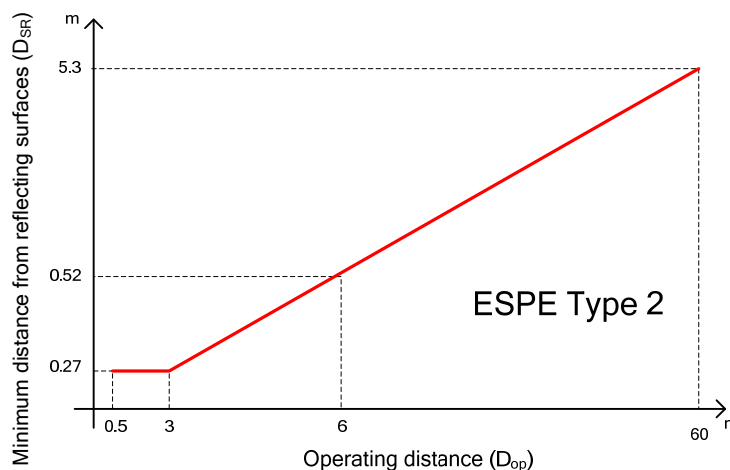

The formula to get  $D_{sr}$  for a Type 2 ESPE is the following:

$$D_{sr} (m) = 0.27 \quad \text{for operating distance} < 3 \text{ m}$$

$$D_{sr} (m) = 0,5 \text{ operating distance (m)} \times \text{tg } 2\alpha \quad \text{for operating distance} \geq 3 \text{ m}$$

2.2.3. 3. Installation of several adjacent safety light curtains

When several safety devices must be installed in adjacent areas, interferences between the emitter of one device and the receiver of the other must be avoided.

Fig.6 provides an example of possible interferences between different devices and two pertinent solutions.

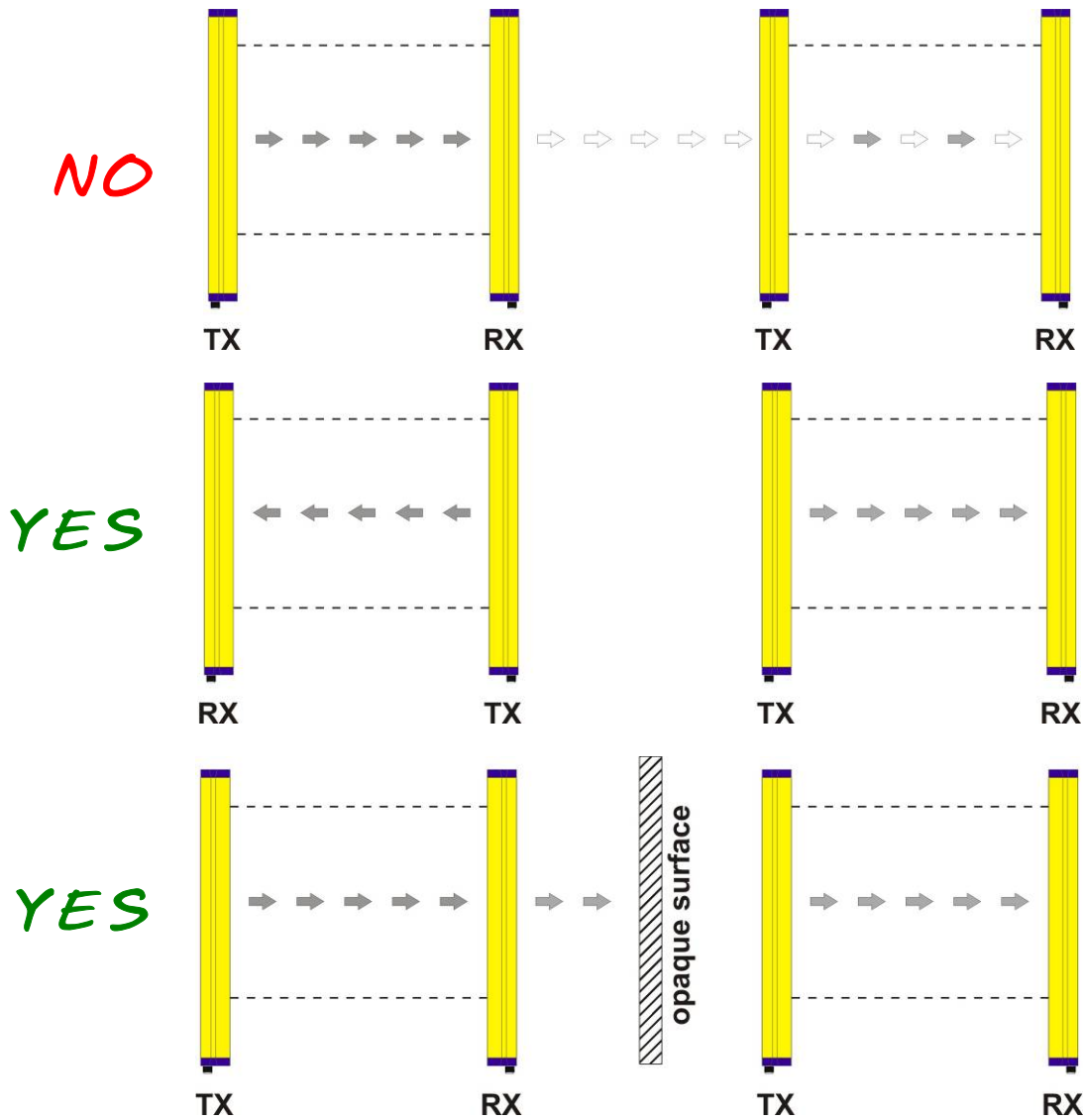

Fig. 6

#### 2.2.4. Use of deviating mirrors

The control of any dangerous area, with several but adjacent access sides, is possible using the linear version without integrated Muting sensors and well-positioned deviating mirrors (see section 12 "Accessories").

Fig.7 shows a possible solution to control three different access sides, using two mirrors placed at a 45° angle respect to the beams.

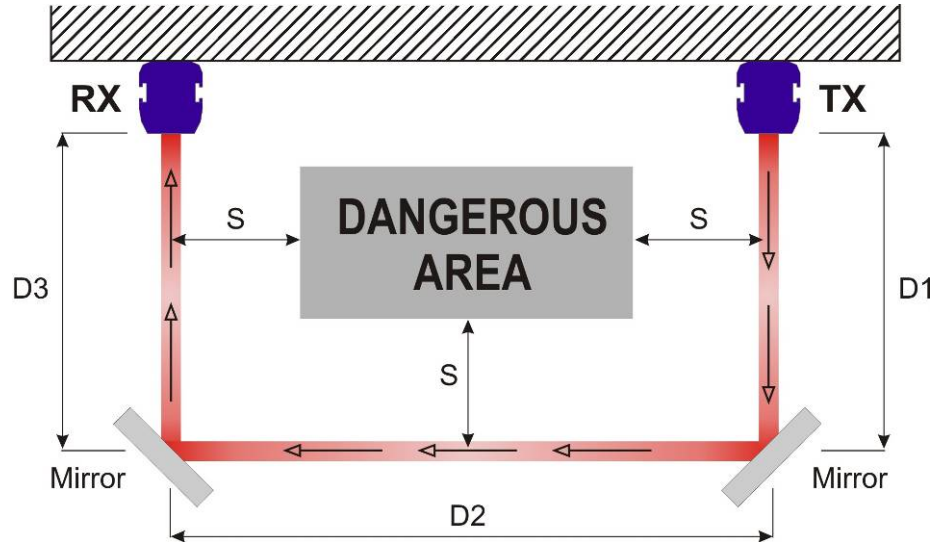

Fig. 7

The operator must respect the following precautions when using the deviating mirrors:

- The alignment of the emitter and the receiver can be a very critical operation when deviating mirrors are used. Even a very small angular displacement of the mirror is enough to lose alignment. A laser pointer (available as an accessory) can be used to avoid this problem.
- The minimum safety distance (S) must be respected for each single section of the beams.
- The effective operating range decreases by about 15% by using only one deviating mirror, the percentage further decreases by using 2 or more mirrors (for more details make refer to the technical specifications of the mirrors used).
- Do not use more than three mirrors for each device.
- The presence of dust or dirt on the reflecting surface of the mirror causes a drastic reduction in the range.

### 2.2.5. Controls after first installation

The control operations to carry-out after the first installation and before machine start-up are listed hereinafter. The controls must be carried-out by qualified personnel, either directly or under the strict supervision of the person in charge of machinery Safety.

Verify that:

ESPE remains in SAFE state (➡) intercepting the beams along the protected area using the specific test piece (TP-40, TP-50, TP-90), following the scheme in the following figure.

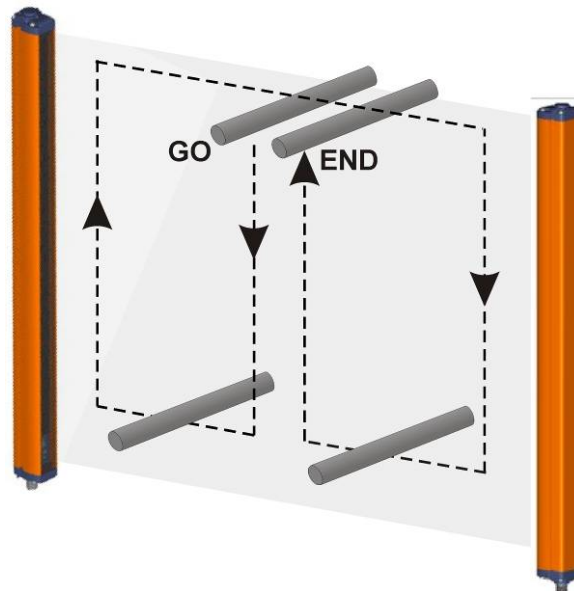

- ESPE has to be correctly aligned, press slightly on the product side in both directions the red LED must not turn on (➡).
- The activation of the TEST function causes the opening of the OSSD outputs (red LED (➡) on and controlled machine stop).
- The response time at machine STOP, including the ESPE and machine response times, must be included in the limits defined in the calculation of the safety distance (refer to paragraph 2.2.1).
- The safety distance between the dangerous parts and ESPE must comply with the requirements indicated in paragraph 2.2.1.
- A person must not access or remain between ESPE and the dangerous parts of the machine.
- Access to the dangerous areas of the machine must not be possible from any unprotected area.
- ESPE must not be disturbed by external light sources, ensuring that it remains in NORMAL OPERATION condition for at least 10-15 minutes and, placing the specific test piece in the protected area, in the SAFE state for the same period.
- Verify the correspondence of all the accessory functions, activating them in the different operating conditions.

### 2.2.5. *Emitter and receiver orientation*

The two units shall be assembled parallel each other, with the beams arranged at right angles with the emission and receiving surface, and with the connectors orientated towards the same direction.

The configurations shown in the following figure must be avoided:

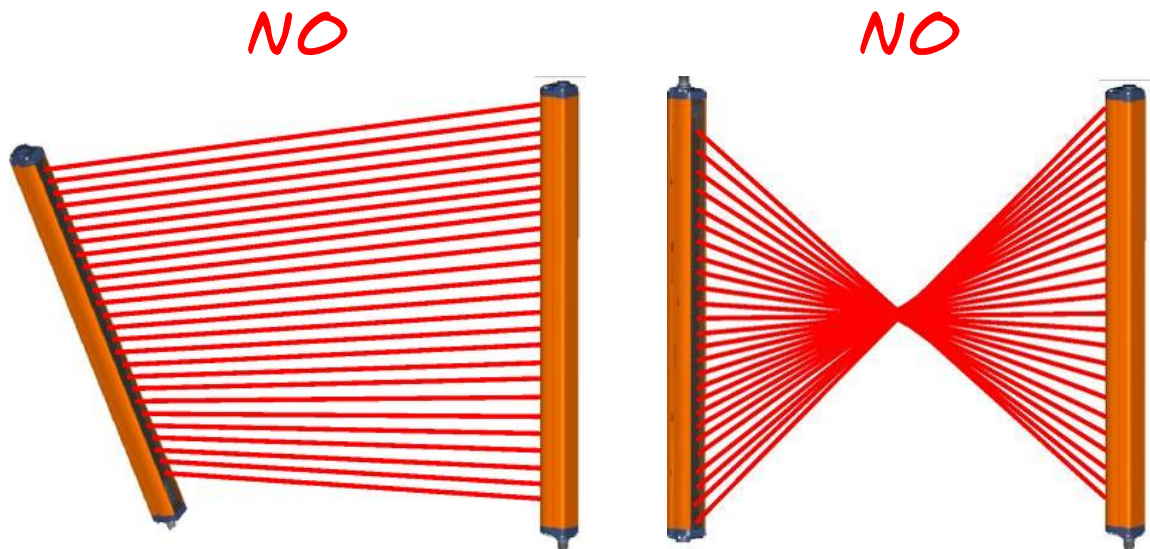

### 3. MECHANICAL MOUNTING

The emitting (TX) and receiving (RX) bars must be installed with the relevant sensitive surfaces facing each other. The connectors must be positioned on the same side and the distance must be included within the operating range of the model used (see section 9 "Technical data").

Once positioned the two units, the two bars should be aligned and parallel as much as possible.

The next step, if necessary, is the fine alignment, as shown in section 5 "Alignment procedures".

To mount the device, use the threaded pins supplied, inserting them into the slots on the two bars (Fig.8 and Fig.9).

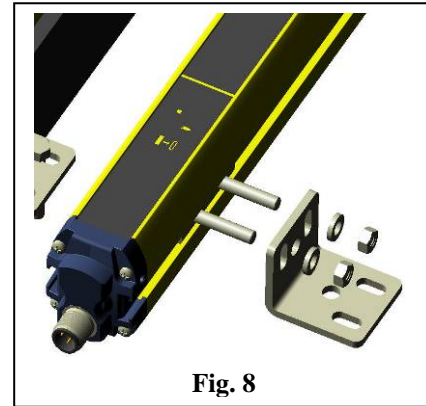

Fixing brackets can be used where no large mechanical compensation is required during the alignment operation.

It is possible to adjust angular position of the light curtain by means of ST-K4ROT-SG BODY COMPACT rotating brackets. The brackets and the round design of the closing caps allow a 360° rotation of the product on its own axis. For further informations see Chapter 12 "Accessories". For further informations refer to chapter 12 "Accessories".

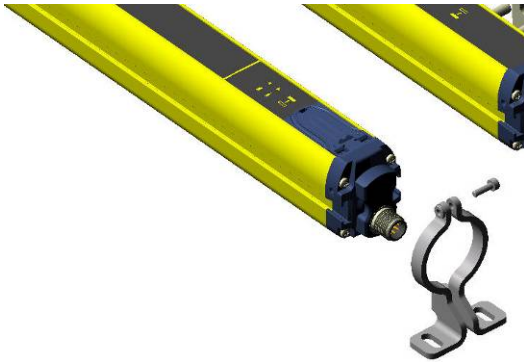

**Fig. 10**

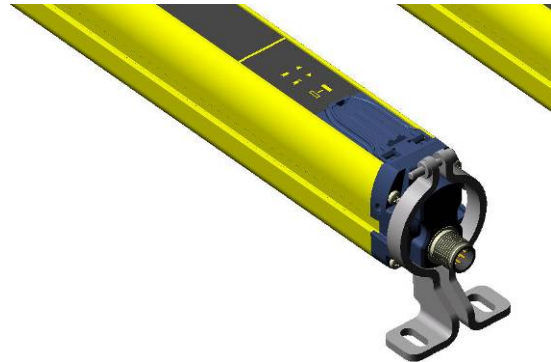

**Fig. 11**

The rotating supports for the correction of the bar inclination of  $\pm 5^\circ$  max. are available on request (see section 12 "Accessories").

In case of applications with particularly strong vibrations, anti-vibration shock absorbers, together with threaded pins, rigid brackets and/or rotating supports, are recommended to reduce the impact of the vibrations.

**4. ELECTRICAL CONNECTIONS**

All electrical connections to the emitting and receiving units are made through a male M12 connector, located on the lower part of the safety light curtain.

**RECEIVER (RX):**

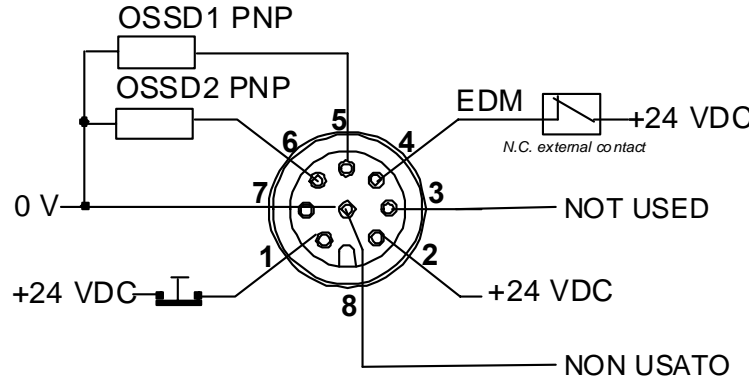

- 1 = white = TEST/START
- 2 = brown = +24 Vdc
- 3 = green = NOT USED
- 4 = yellow = EDM
- 5 = grey = OSSD1
- 6 = pink = OSSD2
- 7 = blue = 0 V
- 8 = red = NOT USED

**EMITTER (TX):**

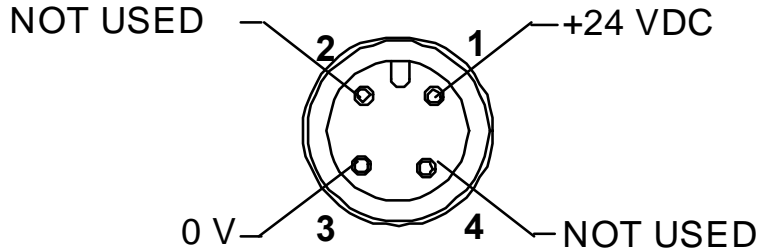

- 1 = brown = +24 Vdc
- 2 = white = NOT USED
- 3 = blue = 0 V
- 4 = black = NOT USED

#### 4.1. Notes on connections

For the correct functioning of the **SAFEasy™** safety light curtains of the SG BODY COMPACT series, the following precautions regarding the electrical connections have to be respected.

- Use only shielded cables for the connection of the two units.
- The light curtain has been developed to offer an adequate immunity level against disturbances in the most critical working conditions.
- It is possible to connect to ground the device housing using the mechanical part supplied for ground connection (refer to configuration illustrated in Fig.12).

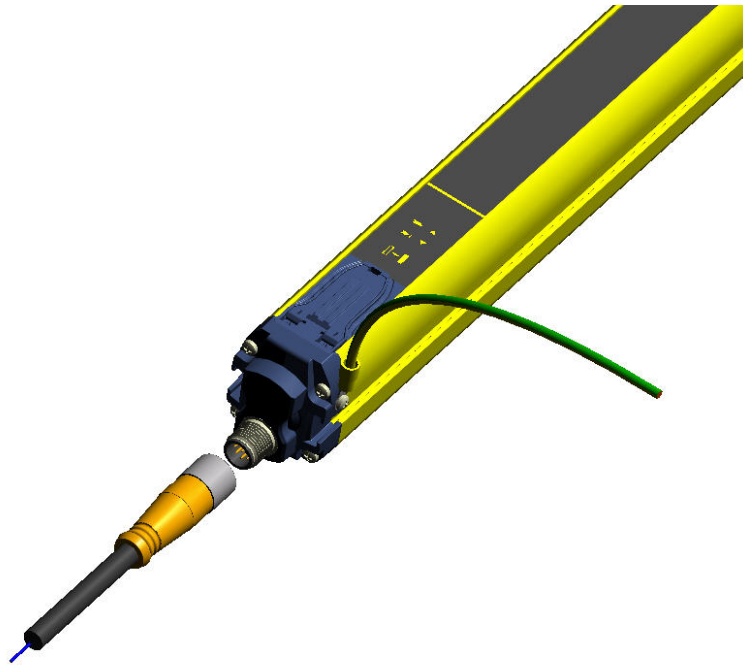

Fig. 12

- Do not place connection cables in contact or near high-voltage cables (e.g. motor power supplies, inverters, etc.);
- Do not connect in the same multi-pole cable the OSSD wires of different light curtains;
- The TEST/START wire must be connected through a N.C. button to the supply voltage of the ESPE. A daily manual test is necessary to verify the correct functioning of the safety light curtain. Push the specific button to activate the test.



- The TEST/START button must be located in such a way that the operator can check the protected area during any Test, Override and Reset operation. (see section 6 "*Functioning mode*").
- The EDM wire has to be connected to a 24 Vdc normally closed contact, before powering. The monitoring function, if selected, is not activated if at powering the wire is not correctly connected; in this case the light curtain enters in a failure condition.
- The device is already equipped with internal overvoltage and overcurrent suppression devices. The use of other external components is allowed but not recommended.

- The ground connection of the two units depends on the electrical protection class to be guaranteed (see section 9 “Technical Data” for more information).

This connection can be carried-out using the screw supplied, which can be put into the proper threaded hole on the cap (see Fig.13).

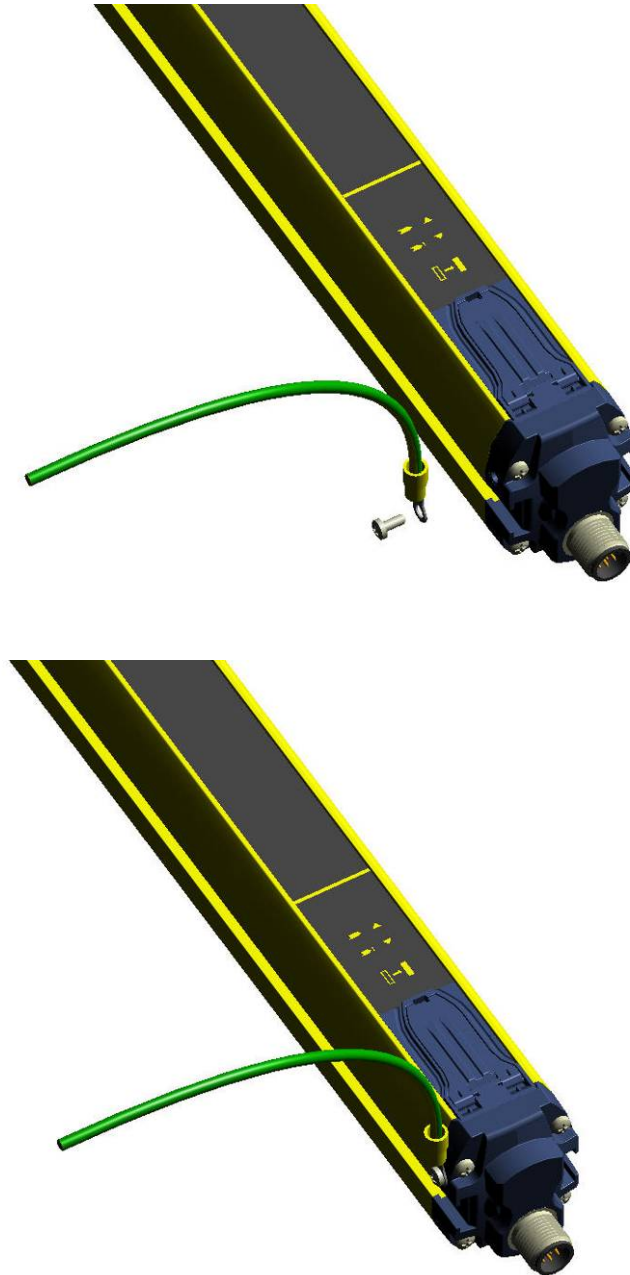

Fig. 13

- The OSSD1 and OSSD2 safety contacts cannot be connected in series or in parallel, but can be used separately (Fig.14). If one of these configurations is erroneously used, the device enters into the output failure condition (see cap.7 "Diagnostic functions").
  - Connect both OSSD to the activating device.
- ⚠ The avoided connection of an OSSD to the activating device jeopardises the system safety degree that the light curtain has to control.

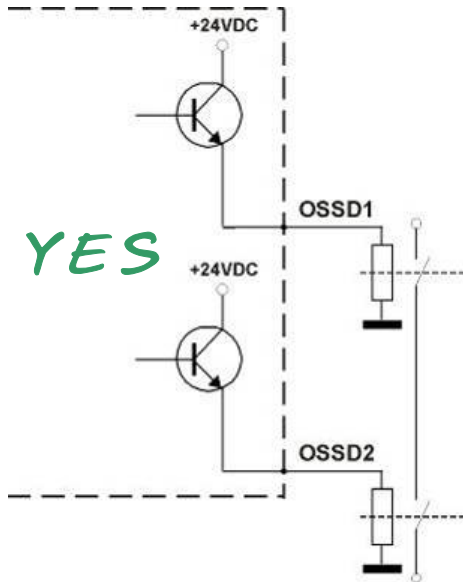

Fig. 14

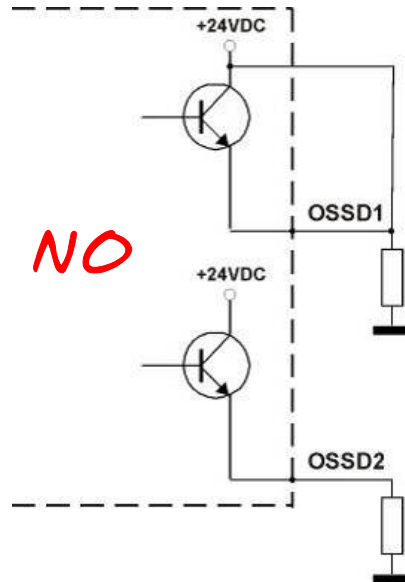

Fig. 15

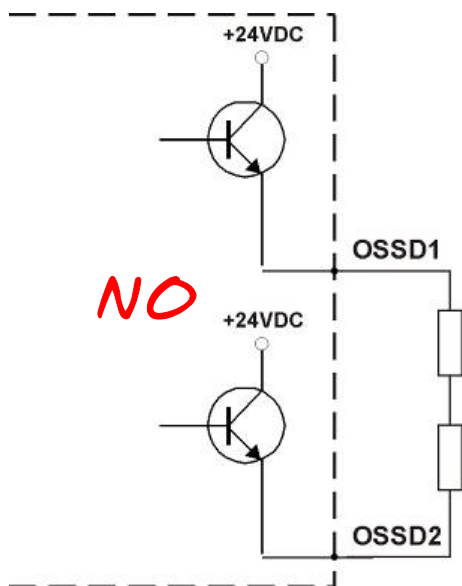

Fig. 16

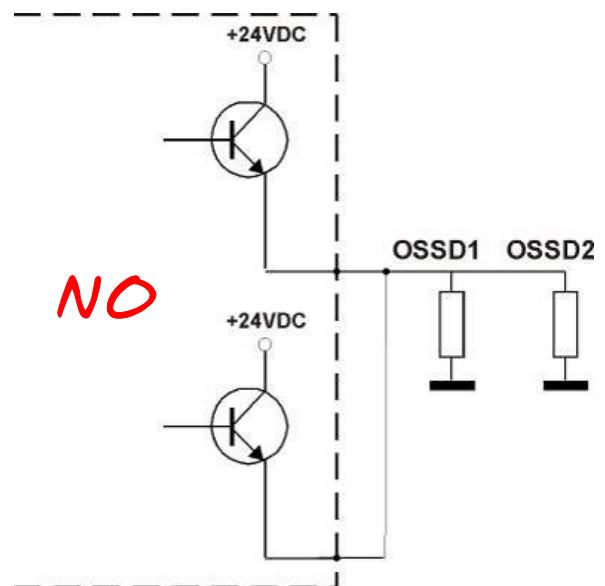

Fig. 17

## 5. ALIGNMENT PROCEDURE

The alignment between the emitting and the receiving units is necessary to obtain the correct functioning of the light curtain.

The alignment is perfect if the optic axes of the first and the last emitting unit's beams coincide with the optic axes of the corresponding elements of the receiving unit. Two yellow LED indicators (HIGH ALIGN, LOW ALIGN) facilitate the alignment procedure.

### 5.1. Correct light curtain alignment procedure

When the mechanical installation and the electrical connections have been effected – as explained in the previous paragraphs – it is possible to carry-out the alignment of the safety light curtain, according to the following procedure:

- Disconnect the power supply to **SAFEasy™**.
- Press the TEST/START button and keep it pressed (open the contact).
- Re-connect the power supply.
- Release the TEST/START button.
- Check the green LED on the bottom of the TX unit (POWER ON) and the yellow LED (NORMAL OPERATION); if they are ON, the unit is running correctly.
- Verify that one of the following conditions is present on the RX unit:
  1. Red LED (SAFE) ON: non-alignment condition.
  2. Green LED (NORMAL OPERATION) ON: light curtain already aligned condition; in this case also the two yellow LEDs will be ON (HIGH ALIGN, LOW ALIGN).
- Continue with the following steps to change from condition 1 to condition 2:
  - A Keep the receiving unit in a steady position and set the transmission unit until the yellow LED on the bottom (LOW ALIGN) is ON. This condition shows the effective alignment of the first lower beam.
  - B Rotate the transmission unit until the upper yellow LED (HIGH ALIGN) is ON; in this conditions red LED (SAFE) must turn off and green LED (NORMAL OPERATION) must turn ON.

**Note:** ensure that the green LED (NORMAL OPERATION) modo is ON and steady.

- C Delimit the area in which the green LED (NORMAL OPERATION) is steady through some micro adjustments - for the first and then for the second unit - then place both units in the centre of this area.
- Fix the two units firmly using pins and brackets.
  - Disconnect the power supply to **SAFEasy™**.
  - Re-connect the power supply.
  - Verify that the green LED is ON on the RX unit (condition where the beams are free, NORMAL OPERATION) and verify that, if even one single beam is obscured, the green LED turns OFF and the red LED turns ON (condition where an object has been detected, SAFE).

## 6. FUNCTIONING MODE

### 6.1. Dip-switch selectable functions

A slot situated in the front side of the RX unit (Fig. 19), that can be easily opened using a screwdriver, facilitates the access to the internal dip-switches.

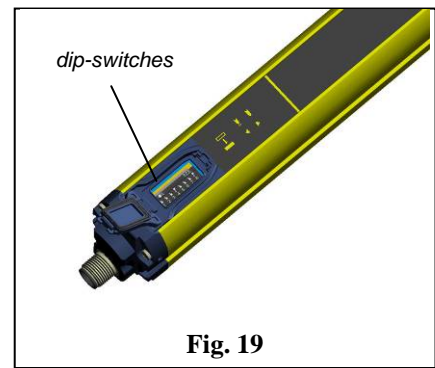
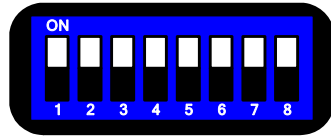
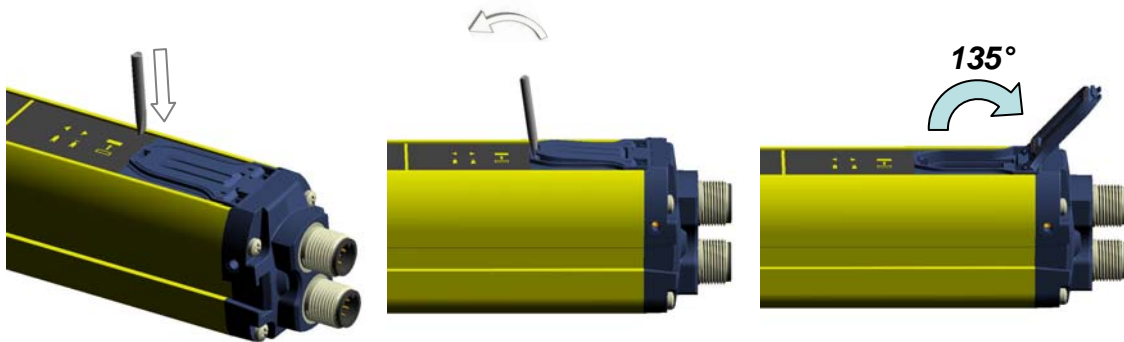

Fig. 19



Insert a screwdriver point into the dedicated pocket of the hinged lid and lever up slightly until the snap happens. Rotate the lid until you reach the 135° angle.

A light brake will provide to keep the wide position.

To close the lid press on the zone where is the pocket until you get the closing snap.

By means of the dip-switches it is possible to set the functions described in the following table:

dip-sw	Function	ON	OFF
1,5	-	-	-
2,6	-	-	-
3,7	EDM	Deactivated	Activated
4,8	Reset	Automatic	Manual

The device does not accept configuration changes during normal functioning. A change is accepted only beginning from the successive powering of the device. Particular attention has to be taken during the configuration dip-switch management and use.

**N.B.:** Like shown in the figure and in the previous table, each functions is associated with two different dip-switches; it is necessary that the two different dip-switches associated to a particular function are configured in the same way.

### 6.2. Standard configuration

The device is supplied with the following standard configuration:

<i>EDM deactivated</i>
<i>Automatic Reset</i>

**Note:** The EDM function can be activated only if the specific input is correctly connected to the appropriate device.

For further details of these functions see sections 6.3 and 6.4.

**6.3. 6.3. Restart mode**

An opaque object detected by the beams causes the switching of the OSSD outputs (i.e. the opening of the safety contacts - SAFE condition).

The restart of the ESPE (i.e. the closing of the OSSD safety contacts – NORMAL OPERATION condition) can be carried-out in two different ways:

- **Automatic Restart:** when an opaque object is detected, the ESPE enters in the SAFE condition. Then, after the opaque object has been removed from the controlled area, the ESPE begins its normal functioning again.
- **Manual Restart:** after the ESPE has detected an opaque object in the controlled area, the light curtain begins its normal functioning again only by pressing the Restart button (TEST button) and after the object has been removed from the controlled area.

*Diagramma temporale (Ripristino Manuale)*

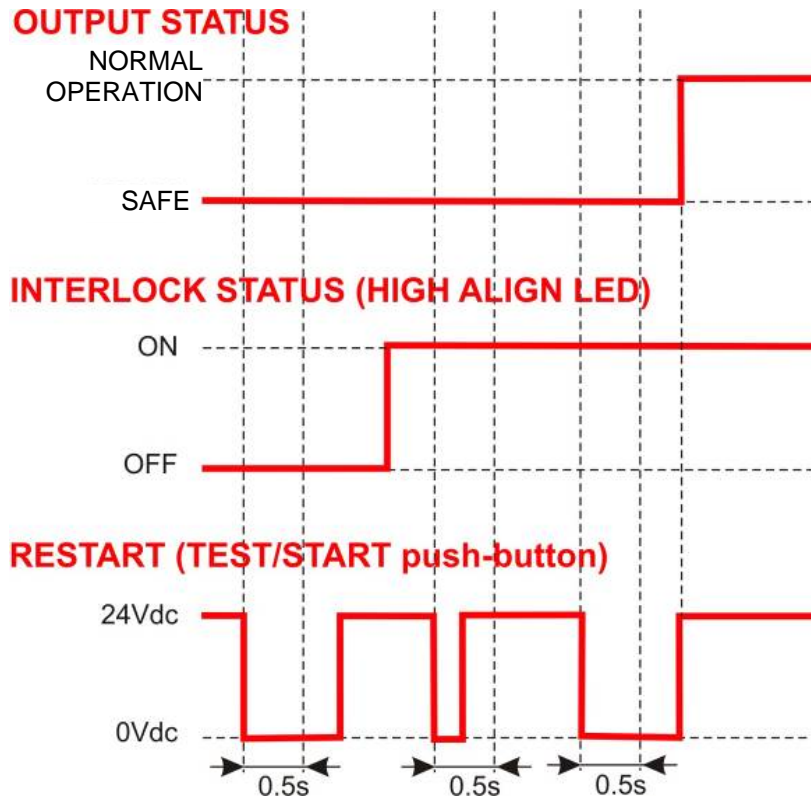

- Fig.20 below shows the two functioning modes:

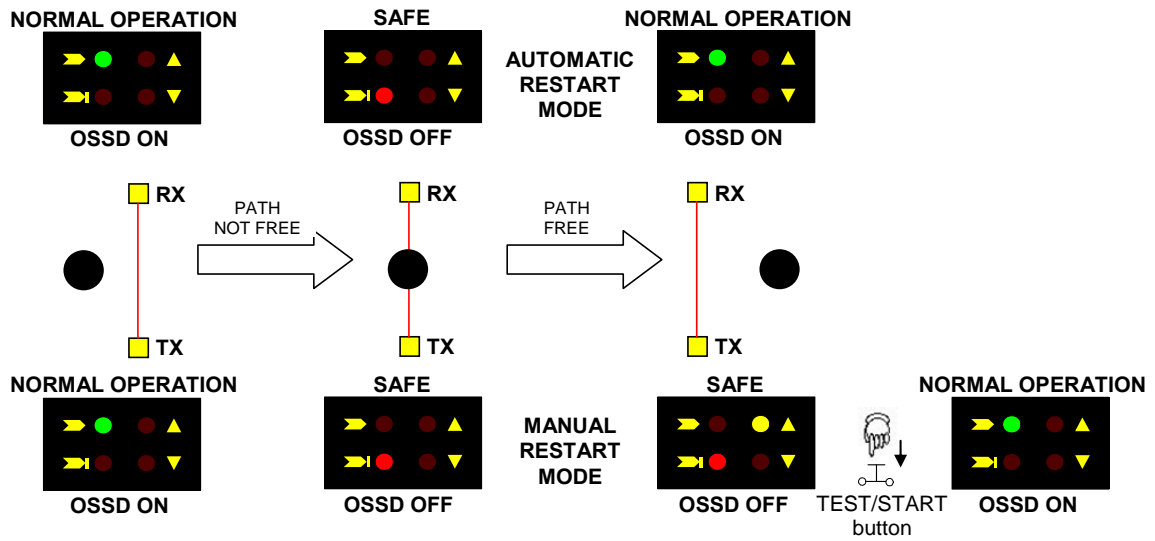
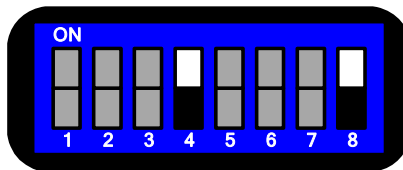

Fig. 20

The selection of the manual/automatic Restart mode is made through the dip-switches placed under the slot of the receiving unit. In particular, 4 and 8 dip-switches must be ON to activate the automatic Restart mode, OFF for the manual Restart mode.



**Note:** The dip-switches not used for this function are in grey. The lever position of the specific dip-switch is in white (ON) in the automatic Restart mode.

**6.4. Test function**

The TEST function can be activated by simply pressing the external push-button for at least 0.5 seconds as shown in the following timing diagram.

AUTOMATIC VERSION

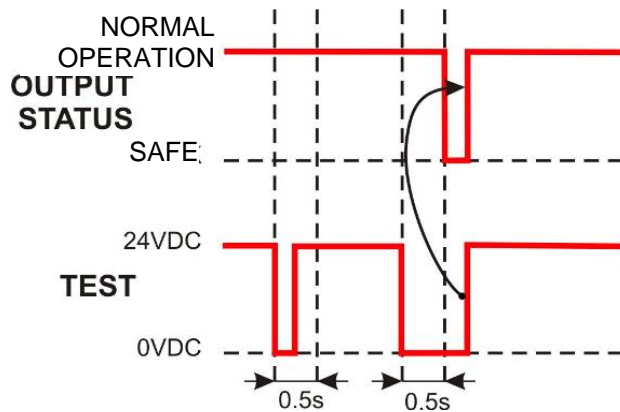

MANUAL VERSION

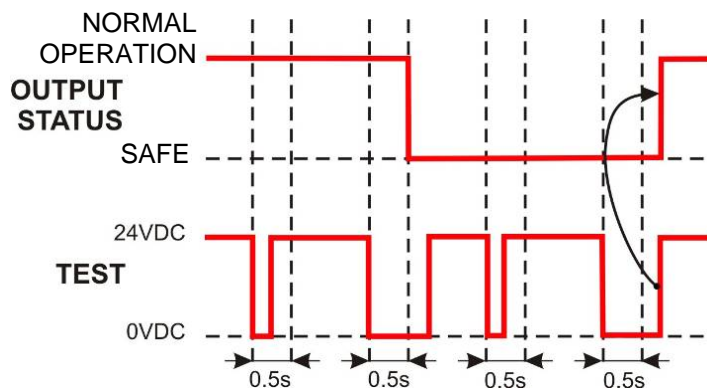

## 6.5. Reset function

The light curtain has a Reset function that is activated in presence of an internal failure. The operator has to press the TEST/START button resetting the break condition and thus return to normal functioning.

The button has to be kept pressed for at least 5 seconds in one of the following conditions:

- *output failure;*
- *optic failure;*
- *failure of the Muting signalling device;*
- *failure of EDM test function.*

Temporal diagram of the Reset function

### Safety light curtain status

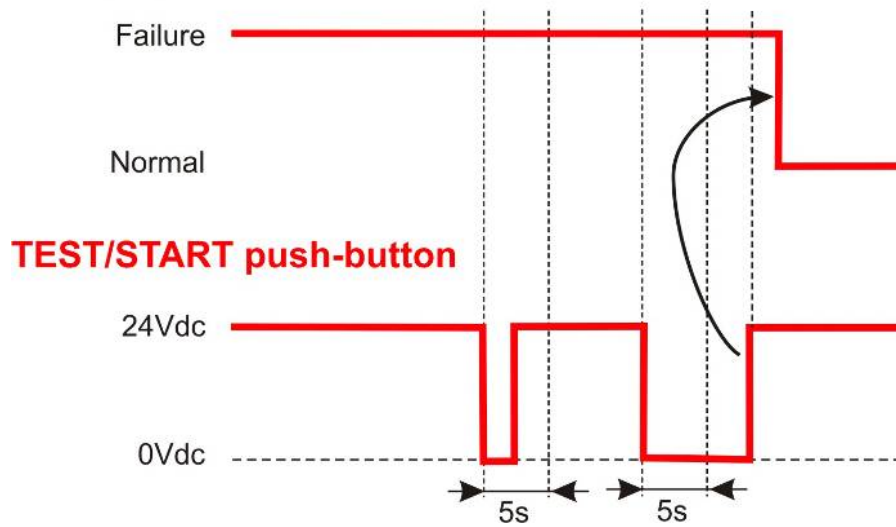

**6.6. EDM function**

The External devices monitoring (EDM) function controls external devices by verifying the OSSD status.

To correctly use this function:

- select it using the specific dip-switches
- connect EDM input to the 24Vdc N.C. contact of the device to control.

The function controls the N.C. contact switching according to the changes of the OSSD status.

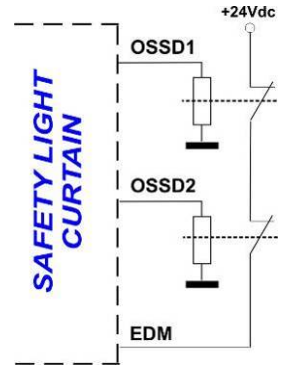

**OSSD STATUS**

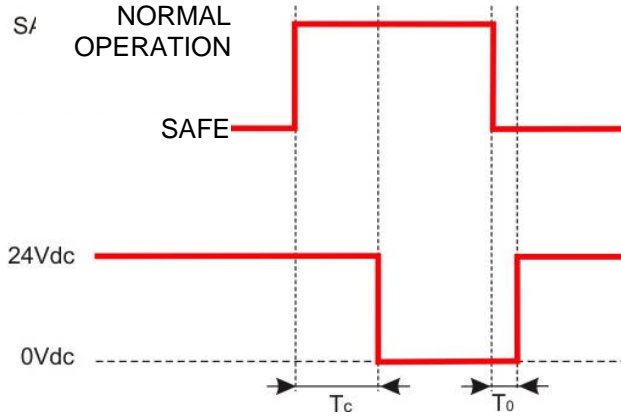

$T_c \geq 350\text{msec}$  time after the OSSD OFF-ON passage when EDM is carried-out  
 $T_0 \geq 100\text{msec}$  time after the OSSD ON-OFF passage when EDM is carried-out

The use of non-conform devices may cause failures.  
 The periodical testing of the function is recommended.

**The correct dip-switch positioning (dip 3 and 7 OFF) for the function activation is shown here aside.**

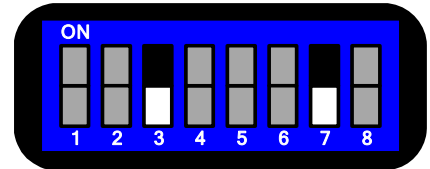

## 7. DIAGNOSTIC FUNCTIONS

### 7.1. Visualisation of the functions

The operator can verify the operating condition of the light curtains through four LEDs positioned on the receiving unit and two LEDs on the emitting unit (Fig.24).

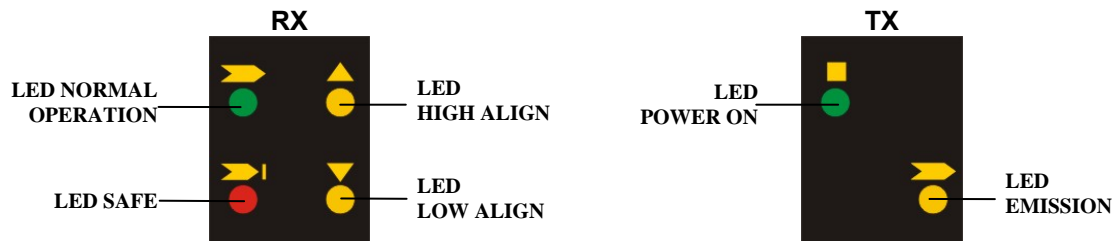

Fig. 24

The meaning of the LEDs positioned on the receiving unit (**RX**) depends on the light curtain operating mode.

## 7.2. Alignment mode

In this condition the outputs are OFF (SAFE state).

- **GREEN LED NORMAL OPERATION**: when ON, indicates that no objects have been detected by the device.
- **RED LED SAFE**: when ON, indicates that the receiving and the emitting units are not aligned, or that an object has been detected.
- **YELLOW LED HIGH ALIGN**: when ON, indicates the correct alignment of the last TX optic with the corresponding RX optic (top side of the device).
- **YELLOW LED LOW ALIGN**: when ON, indicates the correct alignment of the first TX optic with the corresponding RX optic (lower side of the device).

## 7.3. Operating mode

- **GREEN LED NORMAL OPERATION**: when ON, indicates that no objects have been detected by the device.
- **RED LED SAFE**: when ON, indicates that one object has been detected; in this condition the outputs are OFF.
- **YELLOW LED HIGH ALIGN**: when continuously ON, indicates the INTERLOCK state, so that it is necessary to press the TEST/START button to reset the device consequently to an object interception. This occurs only when the device runs under the manual Reset mode.





The LEDs located on the emitter (TX) have the following meanings:

- **YELLOW LED NORMAL OPERATION**: when ON, indicates that the unit is emitting correctly.
- **GREEN LED POWER ON**: when ON, indicates that the unit is correctly powered.



**7.4. Fault and diagnostic messages**

The operator is able to check the main causes of the system stop and failure, using the same LEDs used for the visualization of the functions.

**RECEIVING UNIT:**

Failure	Cause	Check and repair
 <p>OFF      Blinking yellow Blinking red      Blinking yellow</p>	Output failure	<ul style="list-style-type: none"> <li>- Check the output connections.</li> <li>- Check if the load characteristics are in accordance with the Technical data (<i>see section 9</i>)</li> </ul>
 <p>OFF      OFF Blinking red      Blinking yellow</p>	Failure of external switching device (EDM test function)	<ul style="list-style-type: none"> <li>- Control the EDM connections</li> <li>- Check the compatibility of external switching device with EDM test time</li> <li>- Switch OFF and switch ON the devices; if failure persists replace external switching device</li> </ul>
 <p>OFF      Blinking yellow OFF      Blinking yellow</p>	Microprocessor failure	<ul style="list-style-type: none"> <li>- Check the correct positioning of the configuration dip-switches.</li> <li>- Switch OFF and switch ON the device; if the failure continues contact DATALOGIC AUTOMATION</li> </ul>
 <p>OFF      OFF OFF      Blinking yellow</p>	Optic failure	<ul style="list-style-type: none"> <li>- Check unit alignment.</li> <li>- Switch OFF and switch ON the device; if the failure continues contact DATALOGIC AUTOMATION</li> </ul>
 <p>OFF      OFF OFF      OFF</p>	Power supply failure or the power supply voltage is outside the allowed range. Main microprocessor failure	<ul style="list-style-type: none"> <li>- Check power supply.</li> <li>- Switch OFF and switch ON the device; if the failure continues contact DATALOGIC AUTOMATION</li> </ul>

**EMITTING UNIT:**

<b>Failure</b>	<b>Cause</b>	<b>Check and repair</b>
<p><i>ON green</i></p>  <p><i>Blinking yellow</i></p>	<p>Emitter side generic failure</p>	<p>- Check the power supply; if the failure continues contact DATALOGIC AUTOMATION and replace both units</p>
<p><i>OFF</i></p>  <p><i>OFF</i></p>	<p>Power supply failure</p>	<p>- Check the power supply; if the failure continues contact DATALOGIC AUTOMATION.</p>
<p><i>ON green</i></p>  <p><i>OFF</i></p>	<p>The power supply voltage is outside the allowed range Main microprocessor failure</p>	<p>- Check the power supply; if the failure continues contact DATALOGIC AUTOMATION.</p>

## 8. CHECKS AND PERIODICAL MAINTENANCE

The following is a list of recommended check and maintenance operations that should be periodically carried-out by qualified personnel.

- The ESPE stays in SAFE state (➤I) during beam interruption along the entire protected area, using the specific Test Piece (TP-40, TP-50, TP-90). See also section 2 “*Installation Mode*”.
- The ESPE is correctly aligned. Press slightly product side, in both directions and the red LED (➤I) must not turn ON.
- Enabling the TEST function, the OSSD outputs should open (the red LED ➤I is ON and the controlled machine stops).
- The response time upon machine STOP (including response time of the ESPE and of the machine) is within the limits defined for the calculation of the safety distance (see section 2 “*Installation Mode*”).
- The safety distance between the dangerous areas and the ESPE are in accordance with the instructions included in section 2 “*Installation Mode*”
- Access of a person between ESPE and machine dangerous parts is not possible nor is it possible for him/her to stay there.
- Access to the dangerous area of the machine from any unprotected area is not possible.
- The ESPE and the external electrical connections are not damaged.

The frequency of checks depends on the particular application and on the operating conditions of the safety light curtain.

### 8.1. Maintenance



The **SAFEasy™** SG BODY COMPACT safety devices™ do not require any particular maintenance, with the exception of the cleaning of the protection front surfaces of the optics. When cleaning, use a cotton cloth dampened with water.

**Do not under any circumstances use:**

- alcohol or solvents
- wool or synthetic cloths

## 8.2. General information and useful data



The safety devices fulfil their safety function only if they are correctly installed, in accordance with the Standards in force.

If you are not certain to have the expertise necessary to install the device in the correct way, DATALOGIC AUTOMATION Technical Service is at your disposal to carry-out the installation.

Auto-regenerating type fuses are used. Consequently, in presence of a short-circuit, these fuses protect the device.

After the intervention of the fuses, it is necessary to disconnect the power supply and wait for 20 seconds so that the fuses can automatically restart normal functioning.

A power failure caused by interferences may cause the temporary opening of the outputs, but the safe functioning of the light curtain will not be compromised.

## 8.3. Warranty

All appliances are under a 36 month warranty from the manufacturing date.

DATALOGIC AUTOMATION will not be liable for any damages to persons and things caused by the non-observance of the correct installation modes and device use.



The warranty will not cover damages caused by incorrect installation, incorrect use and accidental causes such as bumps or falls.

In presence of a non-functioning device, always return the emitting and receiving units for repair or replacement.

In presence of failures send the both units to DATALOGIC AUTOMATION.

### Sales Technical Service

Tel.: +39 051 6765611

Fax: +39 051 6759324

9. TECHNICAL DATA

Power supply = Vdd:	24 Vdc ± 20% (SELV/PELV)
Internal capacitance:	23 nF (Tx) /120 nF (Rx)
Emitter consumption (TX) S model:	30 mA max / 0.9W
Receiver consumption (RX) S model:	75 mA max (without load) / 2.2W
Outputs:	2 PNP outputs (2 NPN on request) short-circuit protection max: 1.4A at 55°C min: 1.1A at -10°C
Output current:	0.5 A max / each output
Output voltage - ON min:	Vdd -1 V
Output voltage - OFF max:	0.2 V
Leakage current:	< 1mA
Capacitive load (pure):	65 nF max at 25°C
Resistive load (pure):	56Ω min. at 24 Vdc
Response time:	From 14 to 16 ms
Emission type:	Infrared (880 nm)
Resolution:	315 mm (4 beams) 415 mm (3 and 4 beams) 515 mm (2 beams)
Operating distance:	0.5...50 m
Ambient light rejection	IEC 61496-2
Safety category:	Type 4 / Type 2 (ref. EN 61496-1) SIL 3 / SIL 2 (ref. EN 61508) SIL CL 3 / SIL CL 2 (ref. EN 62061) PL e Cat. 4 / PL d Cat. 2 (ref. IEC 13849-1 2008) See chapter 10 "List of available models"
Auxiliary functions:	Restart/EDM/Reset
Operating temperature:	- 10...+ 55 °C
Storage temperature:	- 25...+ 70 °C
Temperature class:	T6 (Tx/Rx/Arm)
Humidity:	15...95 % (no condensation)
Electrical protection:	Class 1 (**refer to note)
Mechanical protection:	IP 65 (EN 60529)
Ambient light rejection:	IEC-61496-2
Vibrations:	0.35 mm width, 10 ... 55 Hz frequency, 20 sweep for each axis, 1octave/min (EN 60068-2-6)
Shock resistance:	16 ms (10 G) 1.000 shock for each axis (EN 60068-2-29)
Housing material:	Painted alluminium (yellow RAL 1003)
Cap material:	PC Lexan 943A
Lens material:	PMMA
Connections:	Tx: conn. M12-4 poles Rx: conn. M12-8 poles
Cable length:	50 m. max (* refer to note) (with 50nF capacitive load and Vdc=24V)
Weight:	1.2 Kg max./m of total height

\* = if a longer cable has to be used, please verify that the same specifications are respected

** Electrical protection	Class 1	Class 3
Protective grounding	Compulsory	Not accepted
Symbol for connection protective grounding	Compulsory	Not accepted
Protection by means of extra-low voltage with protective separation (SELV and PELV)	Recommended	Compulsory

10. LIST OF AVAILABLE MODELS

Model	Length of the sensitive area	Interaxis	N°. Beams	Resolution (mm)	Response time (ms)	Operating distance (m)	Code
SG2-S2-050-PP-E	515	500	2	515	14	0.5..50	
SG2-S3-080-PP-E	815	400	3	415	14	0.5..50	
SG2-S4-090-PP-E	915	300	4	315	16	0.5..50	
SG2-S4-120-PP-E	1215	400	4	415	16	0.5..50	
SG4-S2-050-PP-E	515	500	2	515	14	0.5..50	
SG4-S3-080-PP-E	815	400	3	415	14	0.5..50	
SG4-S4-090-PP-E	915	300	4	315	16	0.5..50	
SG4-S4-120-PP-E	1215	400	4	415	16	0.5..50	

Description	EN ISO 13849-1				Prob. of danger failure/hour	Life span	Mean Time to Dangerous Failure	Average Diagnostic Coverage	Safe Failure Fraction	Hardware Fault Tolerance
	PL	CAT	SIL	SIL CL						
SG2-S2-050-PP-E	d	2	2	2	1.00E-08	20	337	97.00%	98.14%	0
SG2-S3-080-PP-E	d	2	2	2	1.00E-08	20	337	97.00%	98.14%	0
SG2-S4-090-PP-E	d	2	2	2	1.00E-08	20	337	97.00%	98.14%	0
SG2-S4-120-PP-E	d	2	2	2	1.00E-08	20	337	97.00%	98.14%	0
SG4-S2-050-PP-E	e	4	3	3	2.62E-09	20	384	98.90%	99.38%	1
SG4-S3-080-PP-E	e	4	3	3	2.62E-09	20	384	98.90%	99.38%	1
SG4-S4-090-PP-E	e	4	3	3	2.62E-09	20	384	98.90%	99.38%	1
SG4-S4-120-PP-E	e	4	3	3	2.62E-09	20	384	98.90%	99.38%	1

### 11. DIMENSIONS

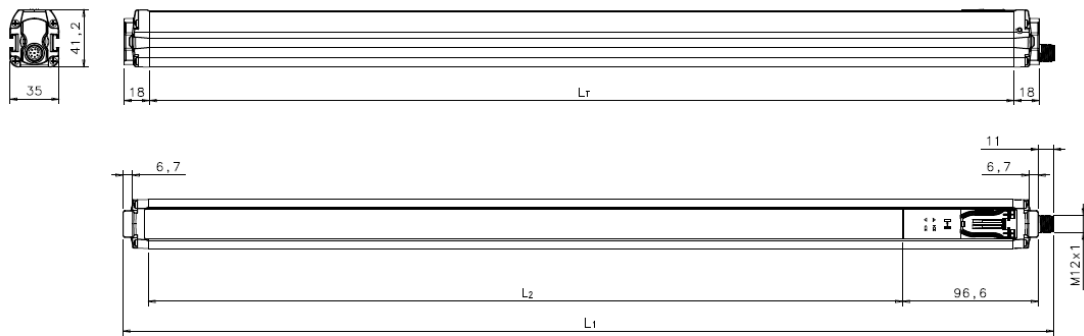

MODEL	Lr (mm)	L1 (mm)	L2 (mm)
SG S2 050	617	664	538,4
SG S3 080	917	964	838,4
SG S4 090	1017	1064	938,4
SG S4 120	1317	1364	1238,4

## 12. ACCESSORIES

### 12.1. Fixing brackets

#### Fixing brackets mounting instructions

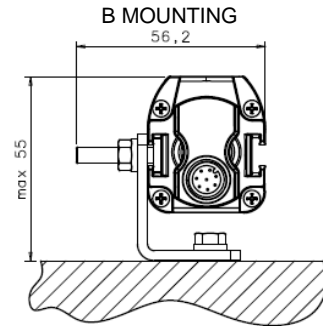
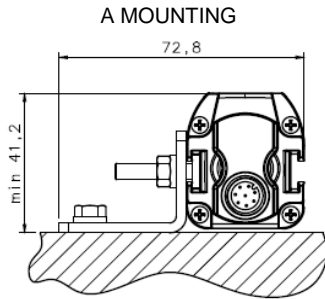

Angled fixing bracket

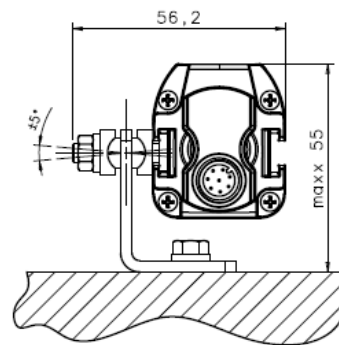
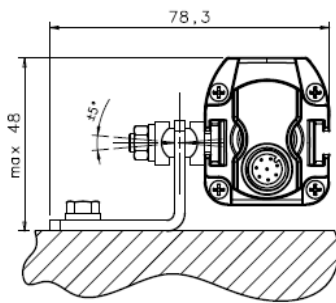

Angled fixing bracket + Orientable support

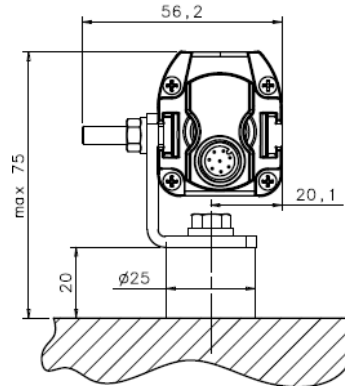
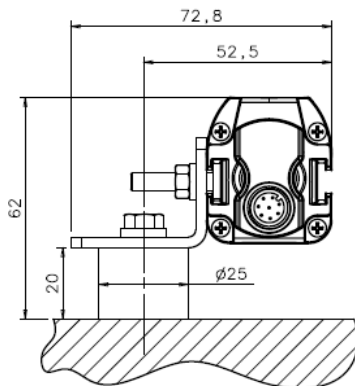

Angled fixing bracket + Antivibration support

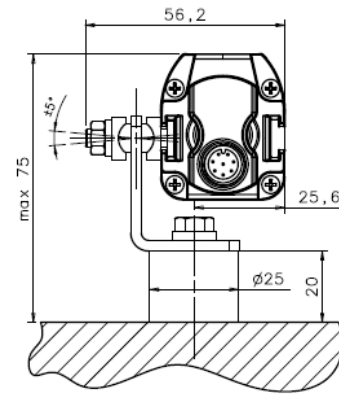
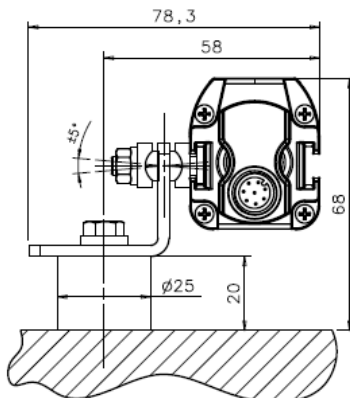

Angled fixing bracket + Orientable support + Antivibration support

MODEL	DESCRIPTION	CODE
ST-KSTD	Fixing brackets for angle mounting (4 pcs kit)	
ST-K4AV	Antivibration support (4 pcs kit)	
ST-K6AV	Antivibration support (6 pcs kit)	
ST-K4OR	Orientable support (4 pcs kit)	
ST-K6OR	Orientable support (6 pcs kit)	

The recommended mounting positions according to the safety light curtain length are shown in the following drawings and table:

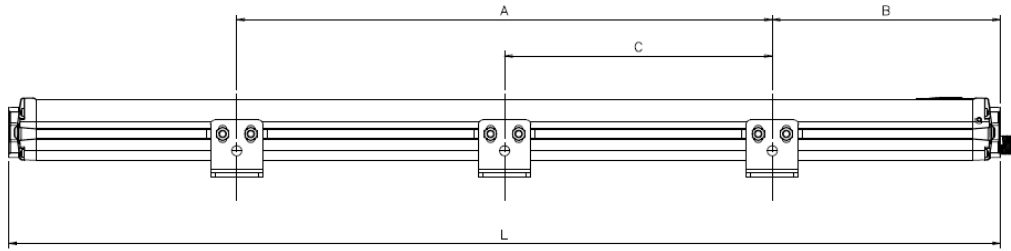

MODEL	L (mm)	A (mm)	B (mm)	C (mm)
SGx-S2-050-PP-E	653	342	150	-
SGx-S3-080-PP-E	953	542	200	-
SGx-S4-090-PP-E	1053	602	220	-
SGx-S4-120-PP-E	1353	942	200	472

x = type2 or type4 models

12.2. Rotating brackets

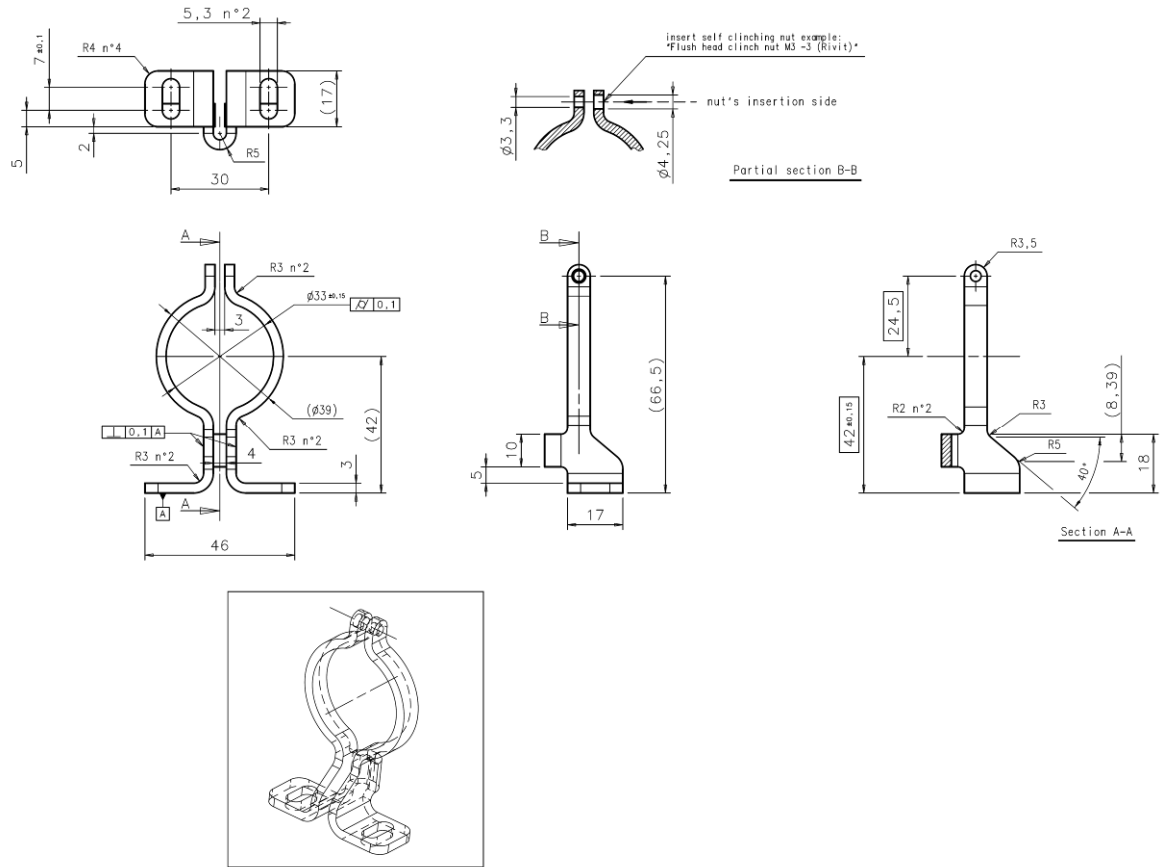

Rotating brackets mounting instructions

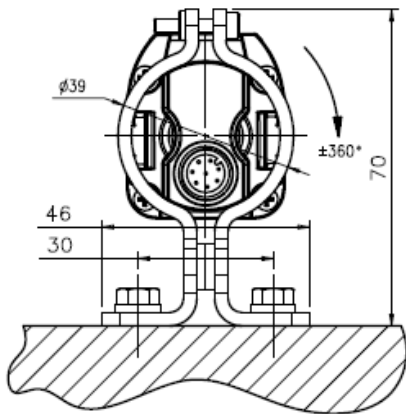

12.3. Deviating mirror

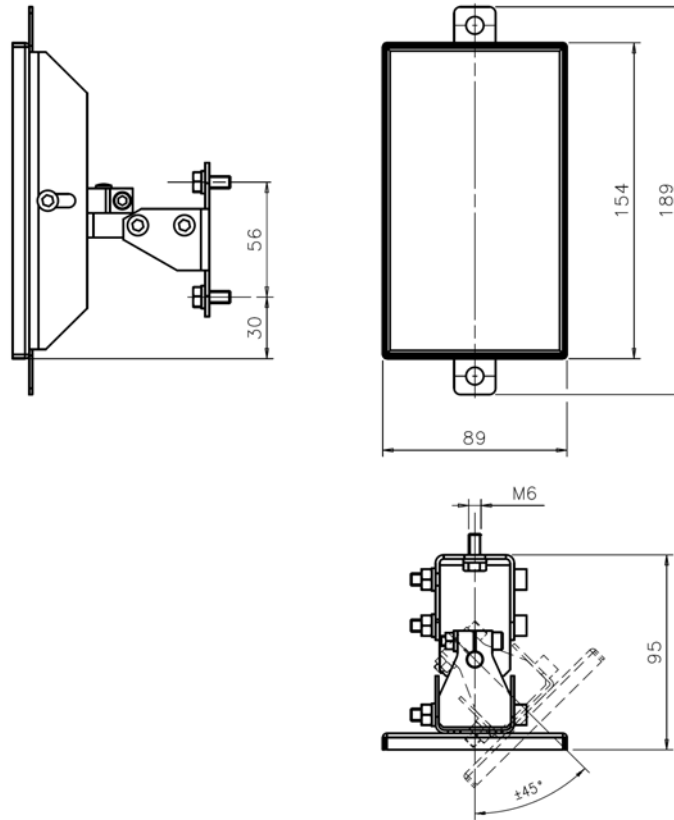

MODELL	DESCRIPTION	CODE
SG-DM 150	Deviating mirror version 150 mm	95ASE1670

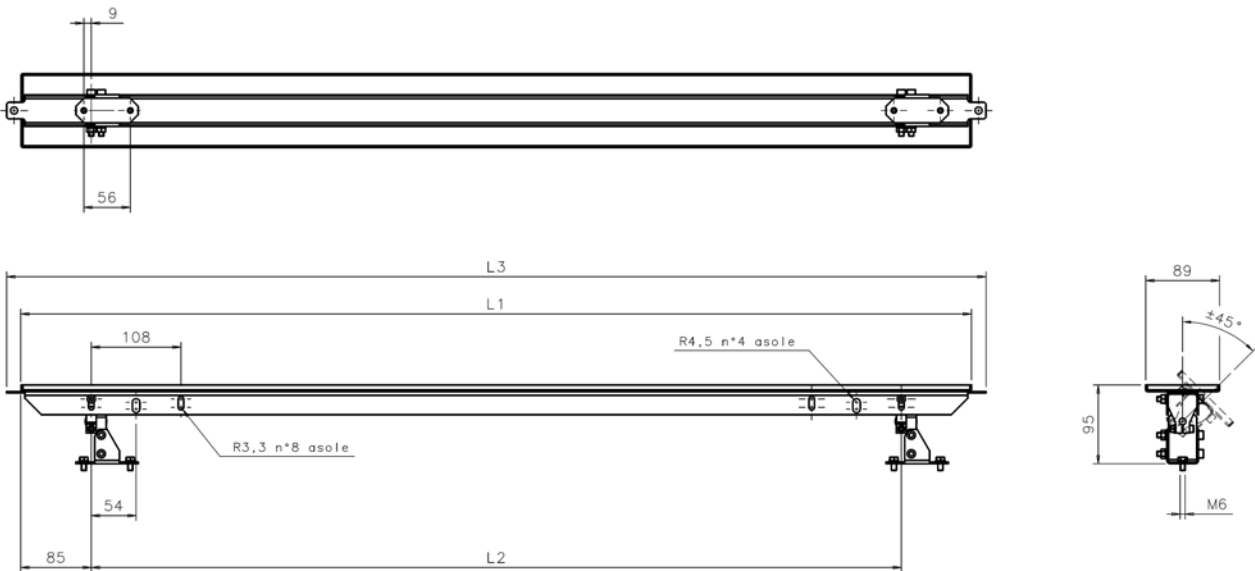

MODEL	DESCRIPTION	L <sub>1</sub> (mm)	L <sub>2</sub> (mm)	L <sub>3</sub> (mm)	CODE
SG-DM 600	Deviating mirror version 600 mm	545	376	580	95ASE1680
SG-DM 900	Deviating mirror version 900 mm	845	676	880	95ASE1690
SG-DM 1200	Deviating mirror version 1200 mm	1145	976	1180	95ASE1700
SG-DM 1650	Deviating mirror version 1650 mm	1595	1426	1630	95ASE1710
SG-DM 1900	Deviating mirror version 1900 mm	1845	1676	1880	95ASE1720

12.4. Column and floor stand

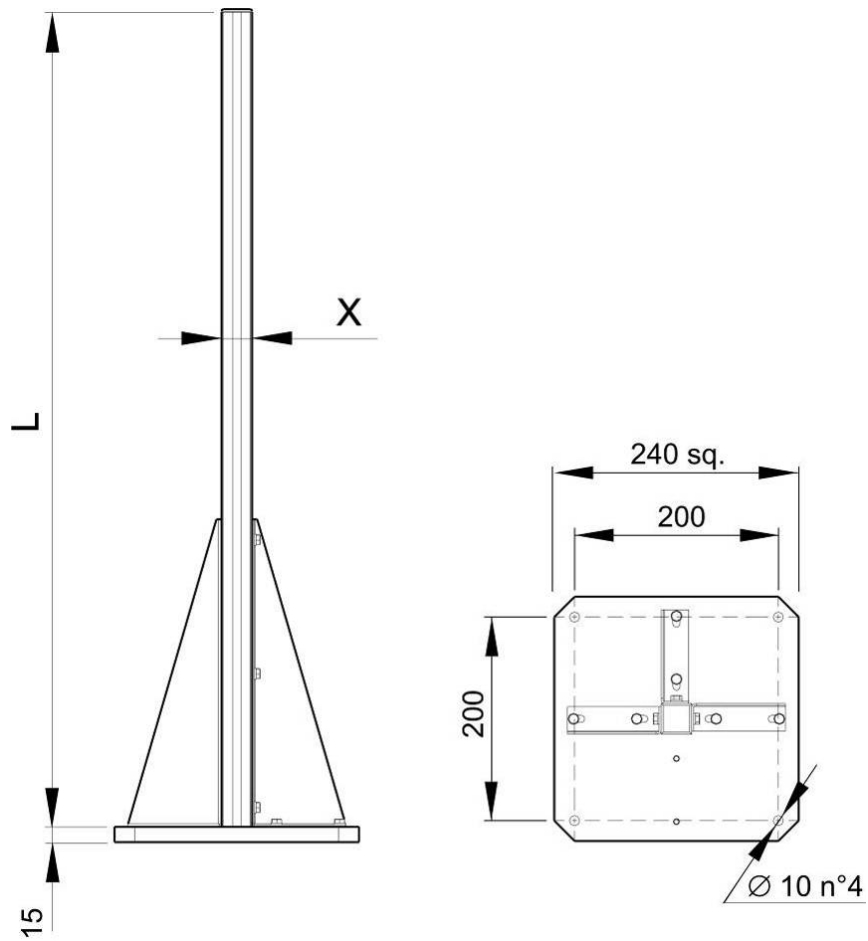

MODEL	DESCRIPTION	L (mm)	X (mm)	CODE
SE-S 800	Column and floor stand H= 800 mm	800	30x30	
SE-S 1000	Column and floor stand H= 1000 mm	1000	30x30	
SE-S 1200	Column and floor stand H= 1200 mm	1200	30x30	
SE-S 1500	Column and floor stand H= 1500 mm	1500	45x45	
SE-S 1800	Column and floor stand H= 1800 mm	1800	45x45	

12.5. Protective stands SE Series

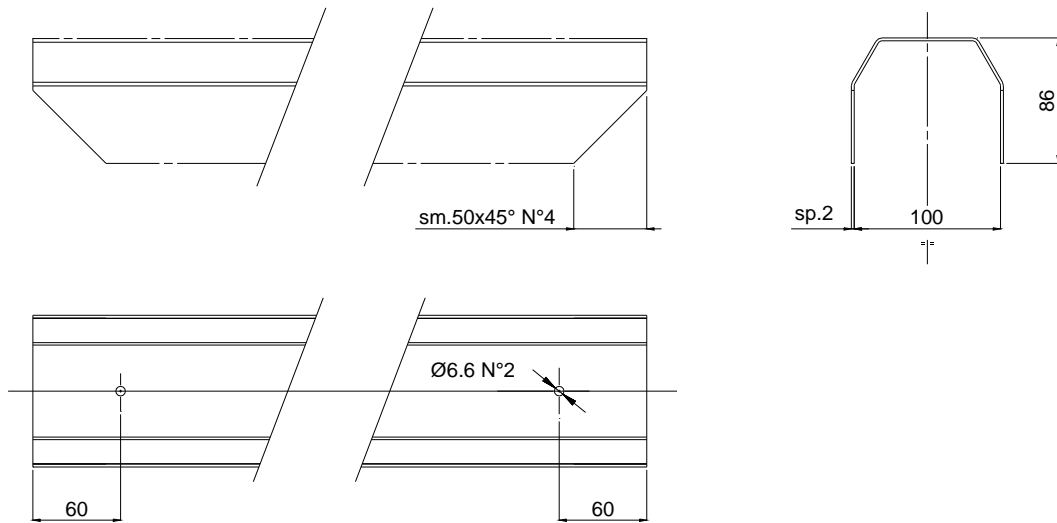

MODEL	DESCRIPTION	L (mm)	CODE
SE-P 150	Protective stand H= 273 mm	273	
SE-P 300	Protective stand H= 420 mm	420	
SE-P 450	Protective stand H= 567 mm	567	
SE-P 600	Protective stand H= 714 mm	714	
SE-P 750	Protective stand H= 861 mm	861	
SE-P 800	Protective stand H= 969 mm	969	
SE-P 900	Protective stand o H= 1069 mm	1069	
SE-P 1050	Protective stand o H= 1155 mm	1155	
SE-P 1200	Protective stand H= 1302 mm	1369	
SE-P 1350	Protective stand H= 1449 mm	1449	
SE-P 1500	Protective stand H= 1596 mm	1596	
SE-P 1650	Protective stand H= 1743 mm	1743	

**12.6. Protective stands SG Series**

SG BODY light curtains can be housed in protective stands, composed by SG-SB and SG-PS accessories.

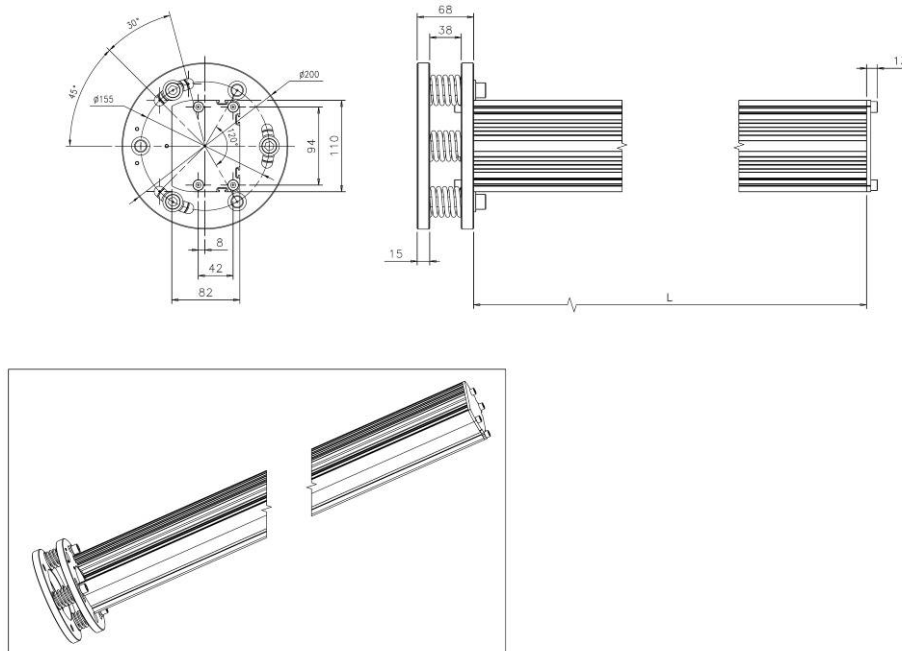

MODEL	DESCRIPTION	CODE
SG-SB	Carter	95ASE1660

MODEL	DESCRIPTION	L (mm)	CODE
SG-PS 600	Protective stand H= 600 mm	600	95ASE1610
SG-PS 900	Protective stand H= 900 mm	900	95ASE1620
SG-PS 1200	Protective stand H= 1200 mm	1200	95ASE1630
SG-PS 1650	Protective stand H = 1650 mm	1650	95ASE1640
SG-PS 1900	Protective stand H = 1900 mm	1900	95ASE1650

12.7. Connection cables

MODEL	DESCRIPTION	CODE
CV-A1-22-B-03	Axial shielded 4-pin 3 m cable	
CV-A1-22-B-05	Axial shielded 4-pin 5 m cable	
CV-A1-22-B-10	Axial shielded 4-pin 10 m cable	
CV-A1-22-B-15	Axial shielded 4-pin 15 m cable	
CV-A1-22-B-25	Axial shielded 4-pin 25 m cable	
CV-A1-26-B-03	Axial shielded 8-pin 3 m cable	
CV-A1-26-B-05	Axial shielded 8-pin 5 m cable	
CV-A1-26-B-10	Axial shielded 8-pin 10 m cable	
CV-A1-26-B-15	Axial shielded 8-pin 15 m cable	
CV-A1-26-B-25	Axial shielded 8-pin 25 m cable	
CV-A2-22-B-03	Radial shielded 4-pin 3 m cable	
CV-A2-22-B-05	Radial shielded 4-pin 5 m cable	
CV-A2-22-B-10	Radial shielded 4-pin 10 m cable	
CV-A2-26-B-03	Radial shielded 8-pin 3 m cable	
CV-A2-26-B-05	Radial shielded 8-pin 5 m cable	
CV-A2-26-B-10	Radial shielded 8-pin 10 m cable	

12.8. SE-SR2 Safety relay

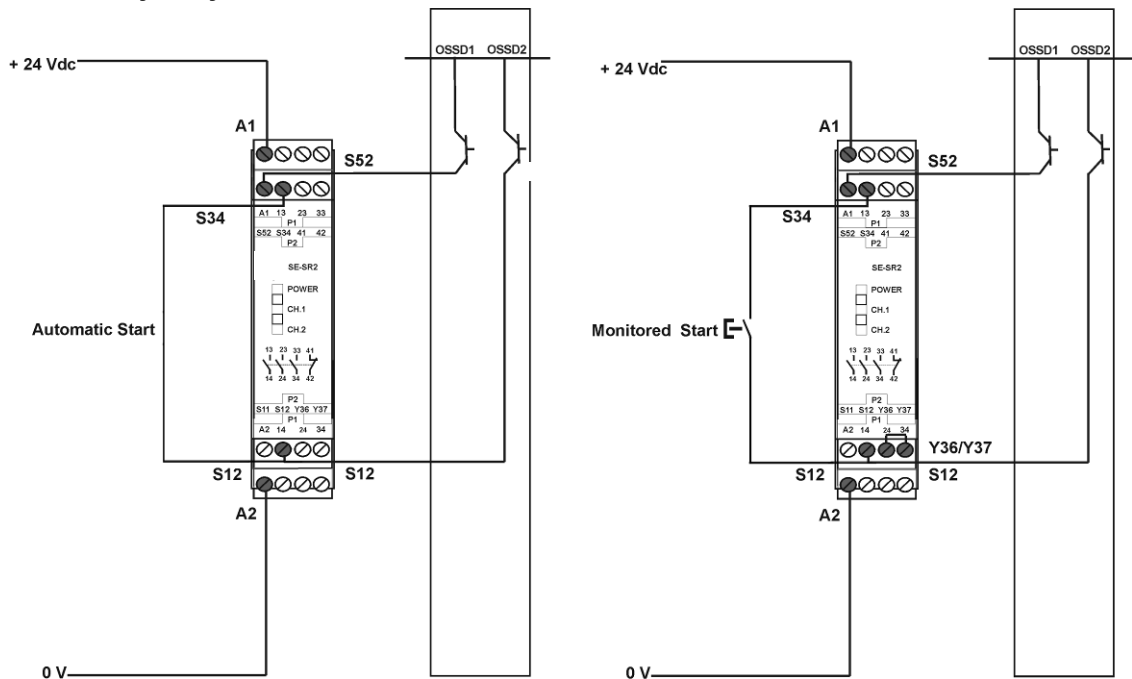

The drawing shows the connection between the **SAFEasy™** safety light curtain and the Type 4 safety relay of the **SE-SR2** series functioning in the automatic Restart mode (left side) and manual Restart with monitoring (right side)

MODEL	DESCRIPTION	CODE
SE-SR2	Type 4 safety relay - 3 NO 1NC	95ACC6170

**EDM Relay Box CSME-03VU24-Y14**

The figures show two practical examples of connection between **SAFEasy™** safety light curtains and **CSME-03VU24-Y14** device.

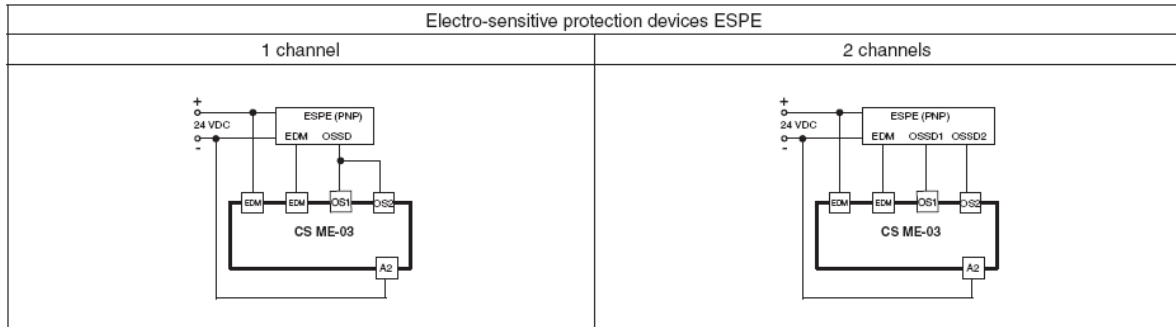

MODEL	DESCRIPTION	CODE
CSME-03VU24-Y14	EDM Relay Box	95ASE1270

**12.9. Test piece**

MODEL	DESCRIPTION	CODE
TP-40	Test piece Ø 40 mm	95ASE1820
TP-50	Test piece Ø 50 mm	95ASE1790
TP-90	Test piece Ø 90 mm	95ASE1800

English

**12.10. Laser pointer**

The laser pointer of the **SG-LP** series represents a valid alignment and installation support for the SG BODY COMPACT safety light curtain series.

The pointer can be moved along the light curtain profile to verify the complete device alignment (top and bottom).

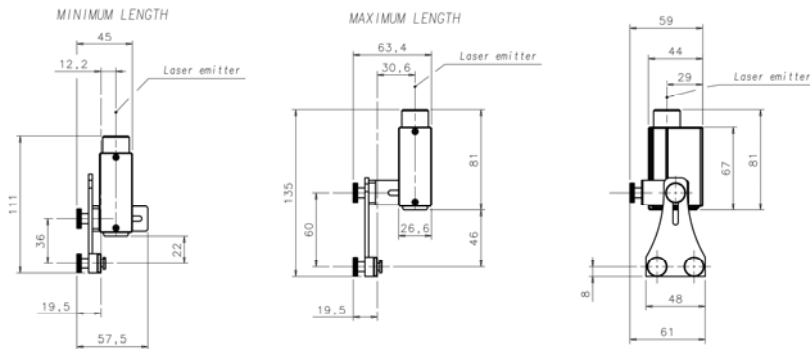
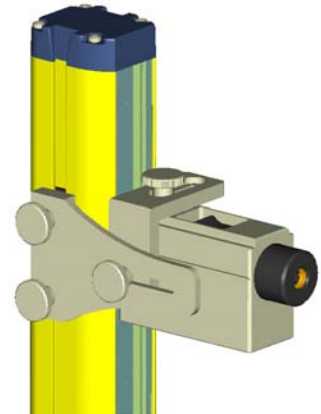

MODEL	DESCRIPTION	CODE
SG-LP	SG-LP Laser pointer	95ASE5590

### 13. GLOSSARY

**ACTIVE OPTOELECTRONIC PROTECTIVE DEVICE (AOPD):** its detection function is achieved thanks to the use of optoelectronic receivers and emitters detecting the optical beams interruptions inside the device caused by an opaque object present inside the specified detecting area.

An active optoelectronic protective device (AOPD) can operate both in emitter-receiver mode and in retro-reflective light curtains.

**BLOCK CONDITION (=BREAK):** status of the light curtain taking place when a suitably-sized opaque object (see DETECTING CAPACITY) interrupts one or several light curtain beams.

Under these conditions, OSSD1 and OSS2 light curtain outputs are simultaneously switched OFF within the device response time.

**BREAK:** see "Block condition" in the glossary.

**CONTROLLED MACHINE:** machine having the potentially-dangerous points protected by the light curtain or by another safety system.

**CROSSING HAZARD:** situation under which an operator crossing the area controlled by the safety device and this latter stops and keeps the machine stopped until the hazard is eliminated, and then enters the dangerous area. Now the safety device could not be able to prevent or avoid an unexpected restart of the machine with the operator still present inside the dangerous area.

**DANGEROUS AREA:** area representing an immediate or imminent physical hazard for the operator working inside it or who could get in contact with it.

**DETECTING CAPACITY:** sensor function parameter limit as specified by the manufacturer, which activates the electrosensitive protection equipment (ESPE). In case of an active optoelectronic protective device (AOPD), with resolution we mean the minimum dimension, which an opaque object must have in order to interrupt at least one of the beams that constitute the sensitive area.

**EDM:** see "External device monitoring" in the glossary.

**ELECTROSENSITIVE PROTECTIVE EQUIPMENT (ESPE):** assembly of devices and/or components working together to activate the protective disabling function or to detect the presence of something and including at least: a sensor, command/control devices and output signal switching devices.

**EMITTER:** unit emitting infrared beams, consisting of a set of optically-synchronised LEDs. The emitting unit, combined with the receiving unit (installed in the opposite position), generates an optical "curtain", *i.e.* the detecting area.

**EXTERNAL DEVICE MONITORING (EDM):** device used by the ESPE to monitor the status of the external command devices.

**FINAL SWITCHING DEVICE (FSD):** part of the control system involving machine safety conditions. It breaks the circuit to the machine primary control element (MPCE) when the output signal switching device (OSSD) becomes inactive.

**FORCE-GUIDED CONTACTS:** Contacts can be guided forcibly when they are connected mechanically so that they can switch simultaneously, when the input stage is active.

If one contact of the series remains "hanged", no other relay contact is able to move.

This function allows the control of the EDM status.

**MACHINE OPERATOR:** qualified person allowed to use the machine.

**MACHINE PRIMARY CONTROL ELEMENT (MPCE):** electrically-powered element having the direct control of machine regular operation so as to be the last element, in order of time, to operate when the machine has to be enabled or blocked.

**MIN. INSTALLATION DISTANCE:** min. distance necessary to allow machine dangerous moving parts to completely stop before the operator can reach the nearest dangerous point. This distance shall be measured from the middle point of the detecting area to the nearest dangerous point. Factors affecting min. installation distance value are machine stop time, total safety system response time and light curtain resolution.

**N.O.:** normally opened

**N.C.:** normally closed

**OFF STATUS:** status when the output circuit is interrupted and does not allow current stream.

**ON STATUS:** status when the output circuit is operational and allows current stream.

**OUTPUT SIGNAL SWITCHING DEVICE (OSSD):** part of the ESPE connected to machine control system. When the sensor is enabled during standard operating conditions, it switches to disabled status.

**PROTECTED AREA:** area where a specified test object is detected by the ESPE.

**PROTECTIVE DEVICE:** device having the function to protect the operator against possible risks of injury due to the contact with machine potentially-dangerous parts.

**QUALIFIED OPERATOR:** a person who holds a professional training certificate or having a wide knowledge and experience and who is acknowledged as qualified to install and/or use the product and to carry out periodical test procedures.

**RECEIVER:** unit receiving infrared beams, consisting of a set of optically-synchronised phototransistors. The receiving unit, combined with the emitting unit (installed in the opposite position), generates an optical "curtain", i.e. the detecting area.

**RESOLUTION:** see "Detecting capacity" in the glossary.

**RESPONSE TIME:** max. time elapsing between the occurrence of the event leading to sensor activation and the reaching of the inactive state by the output signal switching device (OSSD).

**RESTART:** see "Restart Interlocking Device" in the glossary.

**RESTART INTERLOCKING DEVICE:** device preventing machine automatic restart after sensor activation during a dangerous phase of machine operating cycle, after a change of machine operating mode, and after a variation in machine start control devices.

**RISK:** probability of occurrence of an injury and severity of the injury itself.

**SAFETY LIGHT CURTAIN:** it is an active optoelectronic protective device (AOPD) including an integrated system consisting of one or several emitting elements and one or several receiving elements forming a detection area with a detecting capacity specified by the supplier.

**START INTERLOCKING DEVICE (= START):** device preventing machine automatic start if the ESPE is live or the voltage is disabled and enabled once again.

**TEST PIECE:** opaque object having a suitable size and used to test safety light curtain correct operation.

**TYPE (OF ESPE):** the Electrosensitive Protective Equipment (ESPE) have different reactions in case of faults or under different environmental conditions. The classification and definition of the "type" (ex. type 2, type 4, according to IEC 61496-1) defines the minimum requirements needed for ESPE design, manufacturing and testing.

**WORKING POINT:** machine position where the material or semifinished product is worked.