

SG-SRT

The new **SG-SRT** evolves and improves SE-SRT connection box. Based on Datalogic CBX800 GATEWAY housing SG-SRT is developed to fit the advanced functionalities of new SG BODY BIG, SG BODY REFLECTOR and SG BODY COMPACT safety light curtains guaranteeing easy installation, connection, configuration and use. SG-SRT is then provided in 2 different models :

- **SG-SRT-1** version represents the natural replacement of SE-SRT.
- **SG-SRT-2** is especially designed to work together with new SG BODY BIG and SG BODY REFLECTOR series exploiting their full functionalities.



HIGHLIGHTS

- CBX800 housing
- TOTAL COMPATIBILITY WITH SE-SRT
- Two models: SG-SRT-1 and SG-SRT-2
- Fairlead for passage of cables towards the machine
- Integrated FORCE GUIDED SAFETY RELAYS : 2 NO + 1 NC
- Configuration performed setting the various jumpers and connectors on the same PCB

APPLICATIONS

Extreme reliability and simplicity make the SG-SRT the ideal solution for the following applications:

Automatic machines

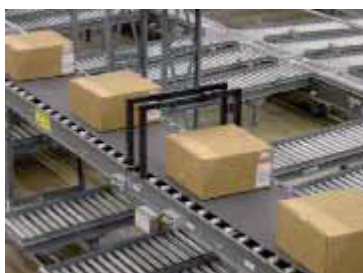

Robots



Automatic assembly lines



Palletizers and depalletizers



DIMENSIONS

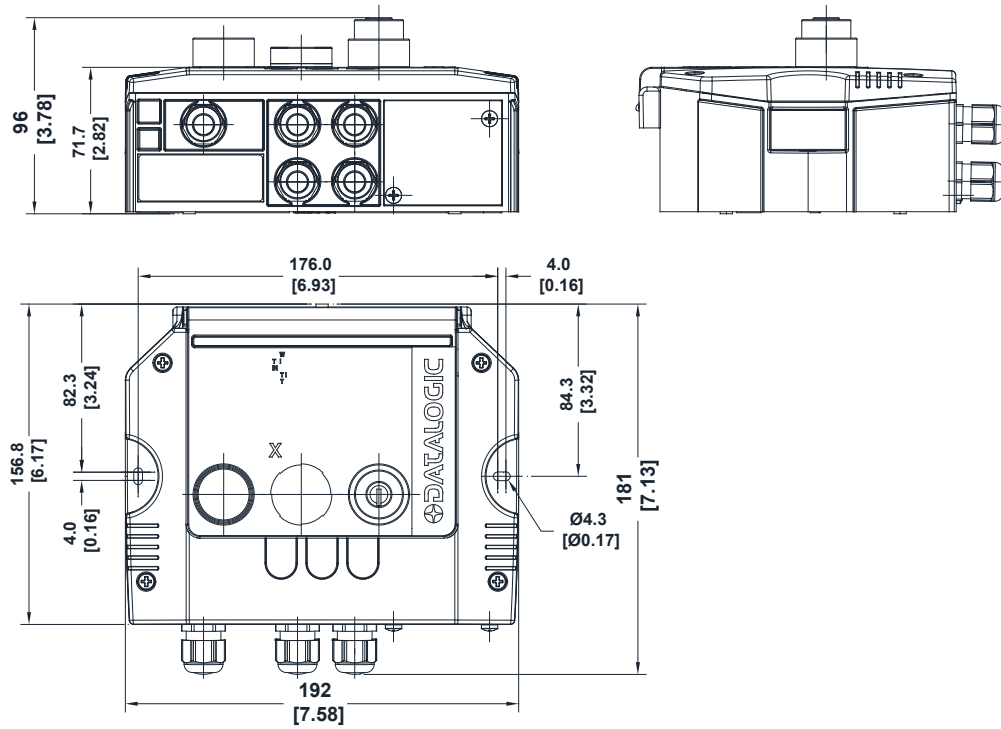

ELECTRICAL CONNECTIONS

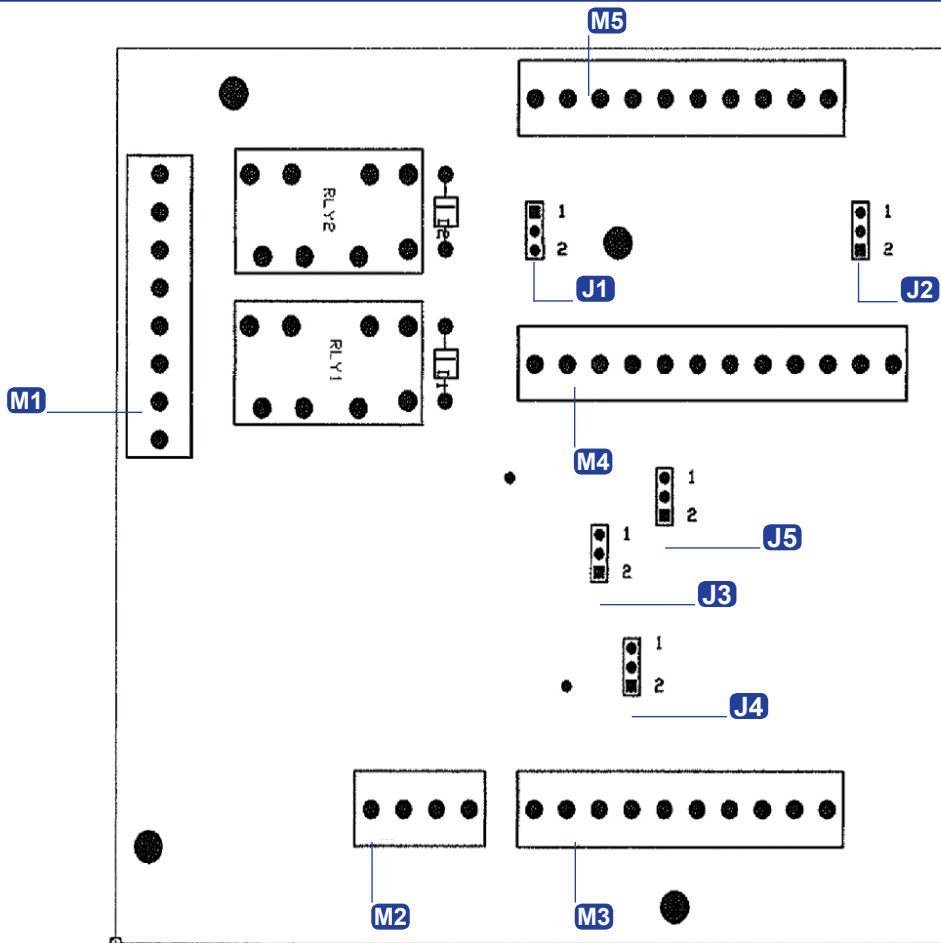

FUNCTIONING

The SG-SRT connection boxes allow you to directly manage, without further action, the following functions according to the typical operation of the connected Safety Barrier model:

FUNCTION	THROUGH
TEST	TEST/START Push button
RESTART	TEST/START Push button
RESET	TEST/START Push button
EDM internal	Internal Selector
EDM external actuators	Internal Selector
OVERRIDE	Key Selector
MUTING STATE	Integrated Lamp (SG-SRT-2 only)

Please refer to the Safety Barrier Manuals for all information regarding connections, operations and options for the functions listed above.

OUTPUT RELAY BEHAVIOUR

The boxes use 2 safety guided relay contacts. These relays are specified by the manufacturer for higher voltages and currents as indicated by the technical data.

However, to ensure correct isolation and prevent premature damage for age drift, you need to protect each output line using a delayed 6A fuse and verify that the load characteristics comply with the instructions below:

Max. switchable voltage: 250 Vac

Max. switchable current: 2 A

CONNECTION BOX AND SAFETY LIGHT CURTAIN CORRESPONDENCE

SAFETY LIGH CURTAIN MODEL	CONNECTION BOX MODEL
SG2 BODY COMPACT BASE	-
SG2 BODY COMPACT MUTING	SG-SRT-1
SG4 BODY COMPACT BASE	-
SG4 BODY COMPACT MUTING	SG-SRT-1
SG2 BODY BIG BASE	-
SG2 BODY BIG MUTING	SG-SRT-1 / SG-SRT-2
SG4 BODY BIG BASE	-
SG4 BODY BIG MUTING	SG-SRT-1 / SG-SRT-2
SG4 BODY REFLECTOR BASE	-
SG4 BODY REFLECTOR MUTING	SG-SRT-1 / SG-SRT-2

MODEL SELECTION AND ORDER INFORMATION

MODEL	DESCRIPTION	ORDER N°
SG-SRT-1	SG-SRT-1 MUTING CONNECTION BOX	95ASE2050
SG-SRT-2	SG-SRT-2 MUTING CONNECTION BOX LAMP	95ASE2060



The company endeavours to continuously improve and renew its products; for this reason the technical data and contents of this catalogue may undergo variations without prior notice. For correct installation and use, the company can guarantee only the data indicated in the instruction manual supplied with the products.

Rev. 0 08/2011