

SG-ONE SERIES

Safeguarding the safety of operators and machines is fundamental in Human Machine Interface (HMI) environments. Enabling switches, emergency stop switches, light curtains, and other safety products are used to guarantee safety, and the **SG-ONE** can effectively monitor and evaluate the safety information from the safety products.

The **SG-ONE** satisfies the highest requirements of key safety standards, such as **Category 4 of EN 954-1, SIL3 of IEC 61508, and PL e of EN ISO 13849-1.**

The innovative safety controller helps implement applications without programming. The operator has to simply select one of the eight logic functions and functioning starts by connecting safety inputs and output equipment.

One SG-ONE module can replace more than five safety relay modules (when configuring a partial or entire stop—Logic 7), reducing cost, wiring, and checking.



HIGHLIGHTS

- Compact housing
- Replacement of single-function modules
- No programming required – simple selection of pre-programmed configurations
- Simple selection of 8 pre-programmed configurations through dip-switches
- 14 safety inputs (6 per double-channel input)
- 4 controlled safety outputs (2 per double channel)
- 2 start inputs
- 10 control outputs
- 2 inputs for solenoid/Muting lamps

APPLICATIONS

Extreme reliability and simplicity make the SG-ONE control units the ideal solution for the following applications:

- Automatic machines/machine tools
- Machines for food packaging
- Automotive
- Automatic assembling lines
- Machines for PCB production



DIMENSIONS

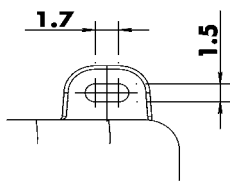
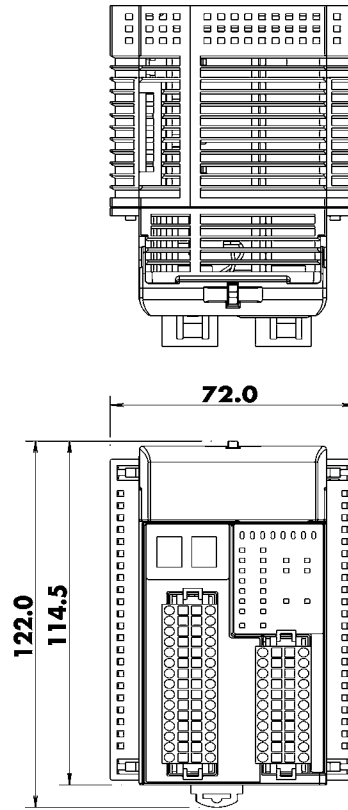
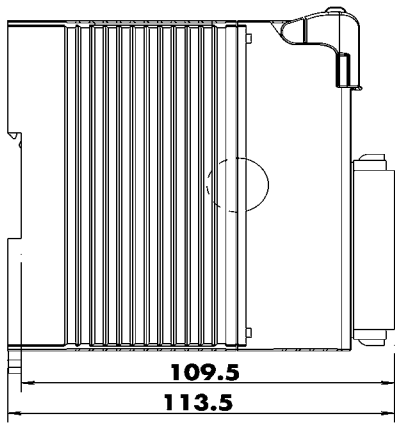

Locking Hole Dimensions(2/1)

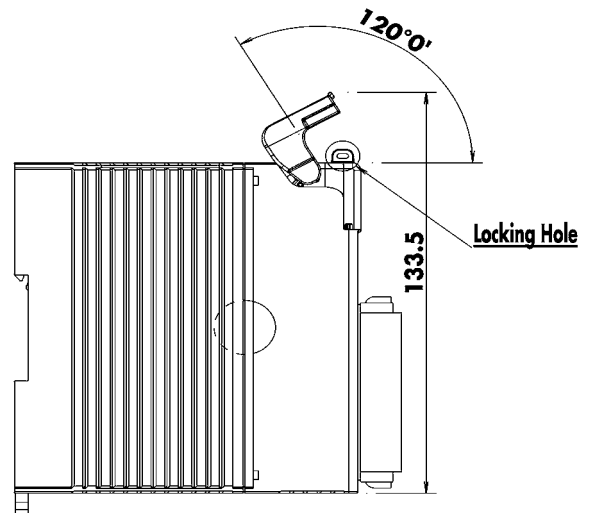

mm

INSTALLATION DRAWING

The following pictures are showing how to install SG-ONE inside machine cabin and/or DIN RAIL.

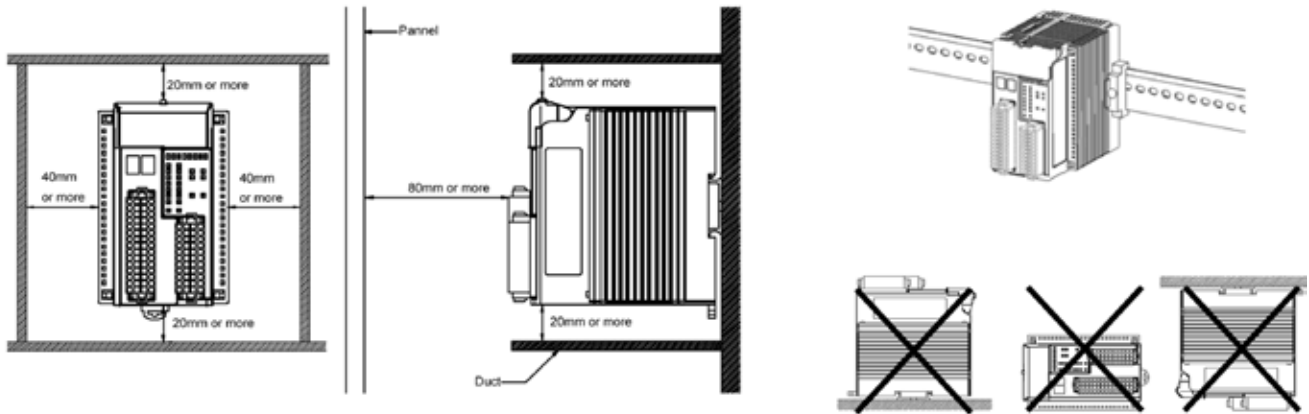

INDICATORS

For detailed information about normal functioning or troubleshooting messages please refer to "INDICATORS" section of the user manual.

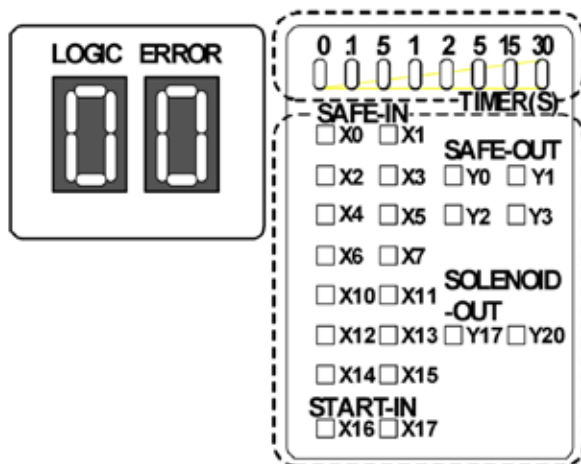

- (1) Logic LED (green)
- (2) Error LED (red)
- (3) Timer LED (green)
- (4) Input/Output status LED (orange)
- SAFE-IN
- START-IN
- SAFE-OUT
- SOLENOID-OUT

CONNECTIONS

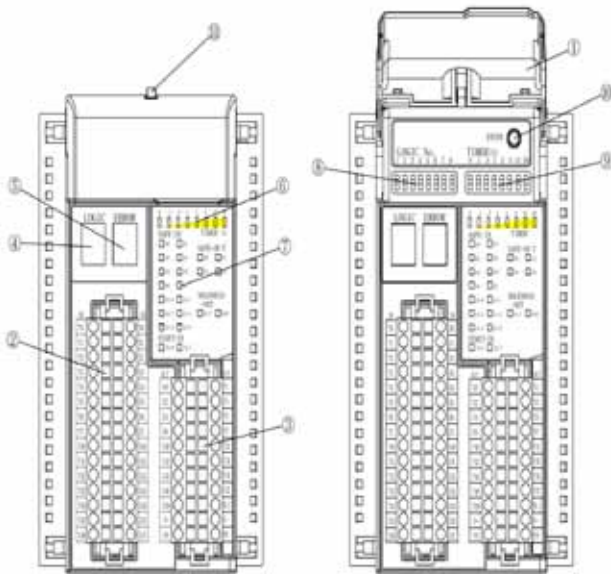

1. Protective cover: The cover protects unauthorized changing of configuration switches by use of a locking hole.
2. Input connector : Spring clamp connector for input devices. (Crimp connector can also be used.)
3. Output connector: Spring clamp connector for output devices and power supply. (Crimp connector can also be used)
4. Logic LED: The 7-segment green LED indicates the number of logic pattern selected.
5. Error LED: The 7-segment red LED indicates an error in the SG-ONE and peripherals.
6. Timer LED: The eight Timer LEDs indicate the selected timer value.
7. Input/output status LED: The input LEDs indicate the state of inputs.
The output LEDs indicate the state of outputs.
 - SAFE-IN: Status of safe inputs, e.g. X0 ... X15
 - START-IN: Status of start inputs, e.g. X16, 17
 - SAFE-OUT: Status of safe outputs, e.g. Y0 ... Y3
 - SOLENOID-OUT: Status of solenoid outputs, e.g. Y17, 20
8. Logic switch: DIP switch for selecting the internal logic.
9. Timer switch: DIP switch for selecting the OFF-delay time for the safe output.
10. Enter button: button for activation of parameter changes.
11. Lock hole: hole for locking the protective cover

SPECIFICATION OF CONFIGURATION SWITCHES

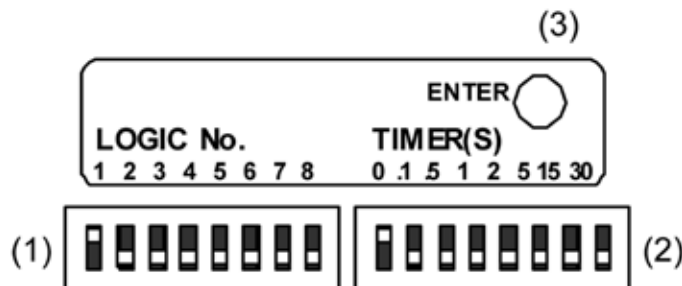

(1) Logic switch

The logic switch is an 8-digit DIP switch for use in logic configuration. When one of 8 digits is selected, the corresponding logic in the SG-ONE is activated. See "Chapter 5 Logic" for further information of each logic. The upper position of each digit is the ON state. Multiple switches must not be selected.

(2) Timer switch

The timer switch is an 8-digit DIP switch for use in OFF-delay timer value configuration. When one of 8 digits is selected, the delay time at shut-off operation is activated. The upper position of each digit is ON state. Multiple switches must not be selected.

(3) Enter button

The enter button is used to activate the configuration of logic and timer value. Error LED will blink for 1 to 5 seconds after pressing the enter button. Releasing the button during blinking activates the setting. The blinking LED becomes ON if the button is pressed for more than 5 seconds, and the setting becomes invalid even after the button is released

Switch	(Indication)	Descriptions
0	1	No OFF-delay (safety outputs shut OFF immediately)
.1	2	OFF-delay timer 0.1s
.5	3	OFF-delay timer 0.5s
1	4	OFF-delay timer 1s
2	5	OFF-delay timer 2s
5	6	OFF-delay timer 5s
15	7	OFF-delay timer 15s
30	8	OFF-delay timer 30s

CONNECTORS

INPUT CONNECTOR - 30 POLE

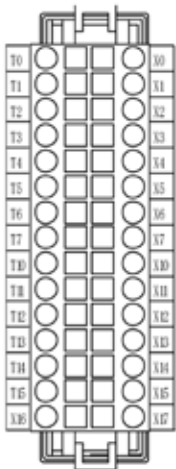

Terminal name	Terminal No.	Description	Terminal name	Terminal No.	Description
T0	A1	Safety input drive terminal 0	X0	B1	Safety input receiver terminal 0
T1	A2	Safety input drive terminal 1	X1	B2	Safety input receiver terminal 1
T2	A3	Safety input drive terminal 2	X2	B3	Safety input receiver terminal 2
T3	A4	Safety input drive terminal 3	X3	B4	Safety input receiver terminal 3
T4	A5	Safety input drive terminal 4	X4	B5	Safety input receiver terminal 4
T5	A6	Safety input drive terminal 5	X5	B6	Safety input receiver terminal 5
T6	A7	Safety input drive terminal 6	X6	B7	Safety input receiver terminal 6
T7	A8	Safety input drive terminal 7	X7	B8	Safety input receiver terminal 7
T10	A9	Safety input drive terminal 10	X10	B9	Safety input receiver terminal 10
T11	A10	Safety input drive terminal 11	X11	B10	Safety input receiver terminal 11
T12	A11	Safety input drive terminal 12	X12	B11	Safety input receiver terminal 12
T13	A12	Safety input drive terminal 13	X13	B12	Safety input receiver terminal 13
T14	A13	Safety input drive terminal 14	X14	B13	Safety input receiver terminal 14
T15	A14	Safety input drive terminal 15	X15	B14	Safety input receiver terminal 15
X16	A15	Start input terminal 16	X17	B15	Start input terminal 17

OUTPUT CONNECTOR - 22 POLE

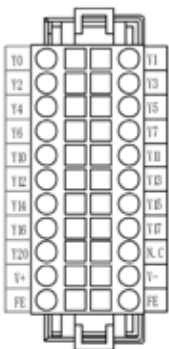

Terminal name	Terminal No.	Description	Terminal name	Terminal No.	Description
Y0	A1	Safety output terminal 0	Y1	B1	Safety output terminal 1
Y2	A2	Safety output terminal 2	Y3	B2	Safety output terminal 3
Y4	A3	Monitor output terminal 4	Y5	B3	Monitor output terminal 5
Y6	A4	Monitor output terminal 6	Y7	B4	Monitor output terminal 7
Y10	A5	Monitor output terminal 10	Y11	B5	Monitor output terminal 11
Y12	A6	Monitor output terminal 12	Y13	B6	Monitor output terminal 13
Y14	A7	Monitor output terminal 14	Y15	B7	Monitor output terminal 15
Y16	A8	Monitor output terminal 16	Y17	B8	Solenoid/lamp output terminal 17
Y20	A9	Solenoid/lamp output terminal 20	N.C	B9	No connection terminal
V+	A10	Power supply 24Vdc terminal	V-	B10	Power supply 0Vdc terminal
FE	A11	Functional ground terminal	FE	B11	Functional ground terminal
T15	A14	Safety input drive terminal 15	X15	B14	Safety input receiver terminal 15
X16	A15	Start input terminal 16	X17	B15	Start input terminal 17

Note: for detailed connections of input devices and output controlled systems refer to section "SETTINGS/LOGICS".



TECHNICAL DATA

GENERAL SPECIFICATIONS

Functioning conditions

Operating temperature (Surrounding air temperature)	-10 - +55°C (without freezing)
Humidity relative to functioning	10 - 95% (no condensation)
Humidity relative to storage	10 - 95% (no condensation)
Pollution degree	2 (IEC/EN 60664-1)
Protection class	IP20 CEI/EN 60529
Corrosion resistance	Atmosphere without corrosive gas
Altitude	Functioning: 0 - 2.000m (0 - 6.565 feet)
	Transport: 0 - 3.000m (0 - 9.840 feet)
Vibration resistance	Clamps (*) 50 m. max Vibrations (IEC/EN 61131-2)
Shock resistance	147 m/s ² (15G), 11ms duration, 3 times per each XYZ axis (CEI/EN 61131-2)
Connector life	50 times max.
Configuration switch strength	100 operations max. (per each switch)
Enter button strength	1000 operations max.
Housing material	m-PPE (modified-Poly Phenylene Ether (m-PPE))
Weight	330g

ELECTRICAL DATA

Rated voltage	24Vdc
Allowed voltage	20.4Vdc to 28.8Vdc
Maximum power consumption	48W (at 24Vdc, all inputs and outputs are ON, includes output loads)
Allowed momentary power interruption	10ms minimum (at rated voltage DC)
Response time	ON to OFF: 40 ms maximum ^{Note1}
	: 100ms maximum ^{Note2}
	OFF to ON: 100 ms maximum ^{Note3}
Start-up time ^{Note4}	6s maximum
Dielectric strength	Between powered part and FE terminal: 500Vac, 1 minute
	Between housing and FE terminal: 500Vac, 1 minute
Insulating resistance	Between powered part and FE terminal: 10MΩ minimum (at 500Vdc megger)
	Between housing and FE terminal: 10MΩ minimum (at 500Vdc megger)
Noise immunity (Noise simulator)	DC power terminals: 1.0 kV, 50 ns to 1 μs
	I/O terminals: 2.0 kV, 50 ns to 1 μs (with coupling adapter)
Inrush current	25A maximum
Ground connection	Type D grounding (Type 3 grounding)
Affect of improper power supply connection	Reverse polarity: No operation, no damage
	Improper voltage: Permanent damage may occur

Note1: Time to shut OFF safety outputs after safety inputs are turned OFF or input monitor error is detected (in case of OFF-delay timer is 0s). If the timer value except 0s, add the selected OFF-delay time to this reaction time.

Note2: Time to shut OFF safety outputs after error (except input monitor error) is detected, or configuration change is detected. This reaction time does not depend on OFF-delay timer value.

Note3: Time to turn ON safety outputs after safety inputs are turned ON (in case of auto start). In case of manual start, it means time turn ON safety outputs after start input is turned ON. In case of control start, it means time to turn ON safety outputs after start input transits from ON to OFF.

Note4: Time to change to Run state after power ON.

Reference standards	DESCRIPTION	ORDER N°
SIL	SIL 3 (CEI 61508) 95ASE1670	
PL	PL e (ISO 13849-1) (Category 4).	
Proof test interval ^{Note1}	Average Probability of Failure on Demand (PFD)	Probability of a dangerous Failure per Hour (PFH)
6 months	< 1,8 x 10 ⁻⁵	< 1,2 x 10 ⁻⁸
1 year	< 3,1 x 10 ⁻⁵	
2 years	< 5,7 x 10 ⁻⁵	
5 years	< 13,4 x 10 ⁻⁵	
Average time until serious failure (MTTF _D)	100 years	
Average diagnostic coverage (DC)	99% or more	

Note1: Refer to Maintenance and Inspection in "Chapter 7 APPENDIX" for proof test procedure.

LOGIC CONFIGURATIONS

The following section is purposed to give some preliminary information about all the logics available and selectable in SG-ONE device.

For detailed information (functions, wiring examples, timing diagrams) please refer to Chapter 5 “Logic” of user manual.

Logic 1

General purpose logic for various apparatuses

This logic is for safety protective measures applicable to production machines, robots, and other apparatuses.

This logic enables the connection 6 dual channel direct opening inputs.

When SG-ONE is in the state which all of the safety inputs can receive the safety input signals (all contacts of the connected safety devices are ON), safety outputs are turned ON upon input of the start input. During the time the safety outputs are ON, if any safety input signal to any input of the safety inputs is turned OFF (the contacts of the safety devices are OFF), the safety outputs are turned OFF after the preset OFF-delay time.

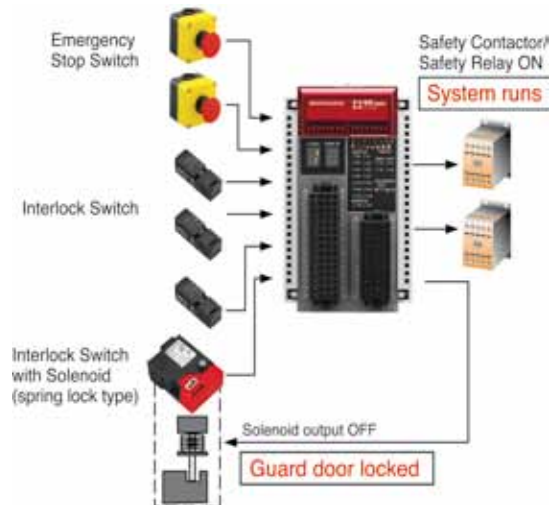

Logic 2

General purpose logic for NO/NC contact inputs

This logic function is for using dual channel NO/NC contact devices as safety protective measures for semiconductor manufacturing machines, food packaging machinery, and other machinery. This logic has 4 dual channel inputs for NO/NC contact devices and 2 dual inputs for direct opening inputs.

When all of the safety inputs are in the safe state (for NO/NC contact devices: NO contacts are ON and NC contacts are OFF (actuators are in installed in the interlock switches), for direct opening devices: all contacts are ON), safety outputs are turned ON with the start input. While the safety outputs are ON, if the safe state of any safety input devices is broken (for NO/NC contact device: NO contact is OFF or NC contact is ON (actuator is removed from interlock switch), for direct opening inputs: contact is OFF), the safety outputs are turned OFF after the preset OFF-delay time.

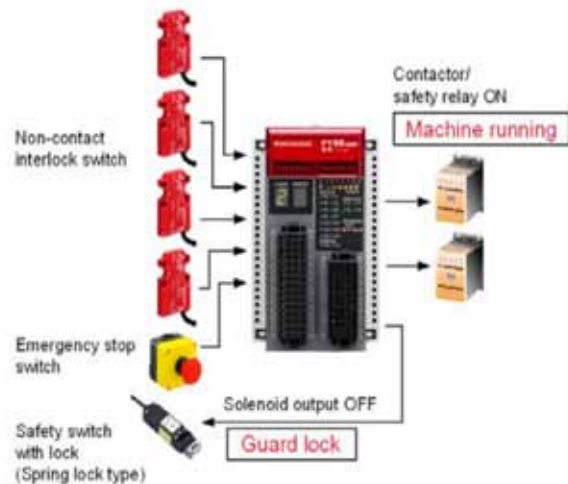

LOGIC CONFIGURATIONS

Logic 3

General purpose logic for machines with openings

This logic is for using safety devices with dual channel solid state outputs, such as safety light curtains, for safety protective measures of production machinery, robots, and other machinery. This logic enables the connection of 2 dual channel solid state output (PNP) devices and 4 dual channel direct opening inputs.

When in this state all of the safety inputs are receiving safety input signals (24V DC is applied from the solid state output devices, and the all contacts of contact devices are closed), the safety outputs are turned ON upon input of the start input. If any of the safety input signals is cut OFF while the safety outputs are ON, the safety outputs are turned OFF after the preset OFF-delay time.

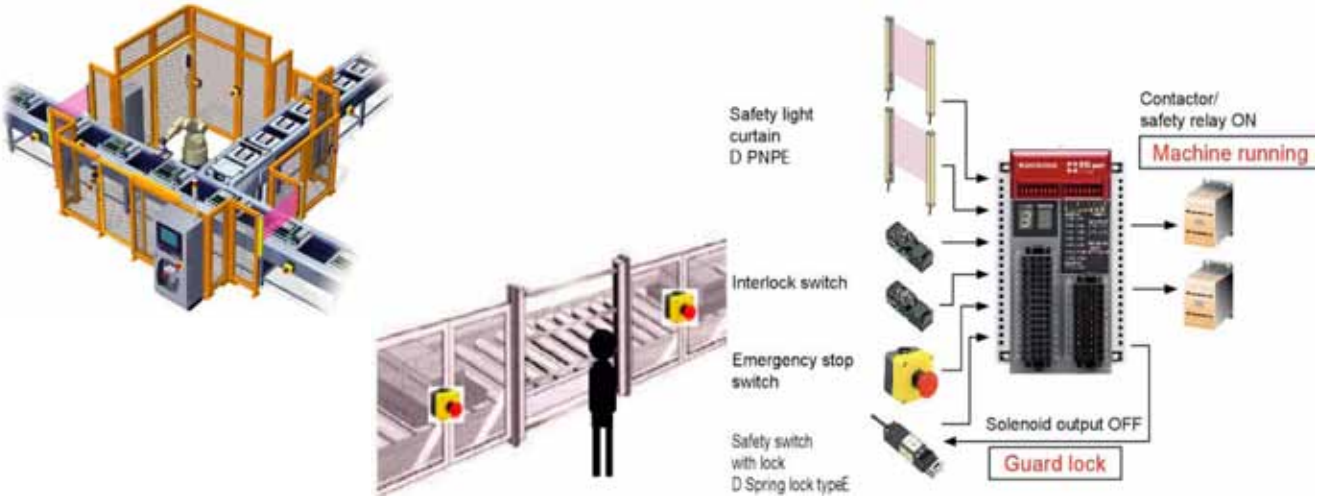

Logic 4

Muting function logic for machines with openings

The logic described is for using safety devices with dual channel solid state outputs, such as safety light curtains (Ex. SG2, SG4, SG BODY and SE series), and for devices with output muting signals that enable muting functions that temporarily suspend safety functions of safety devices for safety protective measures of robots, conveyor lines, and other machines. This logic enables the connection of 2 dual channel solid state output (PNP) devices, 2 muting signal output (PNP) devices (Ex. S3Z, S8, S60, S300 Muting sensor series, limit switch), and 2 dual channel direct opening inputs.

When all of the safety inputs (X0, X1, X4, X5, and X10 to X13) are receiving safety input signals (24V DC is applied from the solid state output devices, and the all contacts of connected devices are closed), the safety outputs are turned ON upon input of the start input.

If any of the safety input signals are cut OFF while the safety outputs are ON, the safety outputs are turned OFF after the preset OFF-delay time. However, if a muting signal has been applied to X2 and X3 (X6 and X7), the safety output does not turn OFF even if the safety inputs signal to X0 and X1 (X4 and X5) are cut OFF.

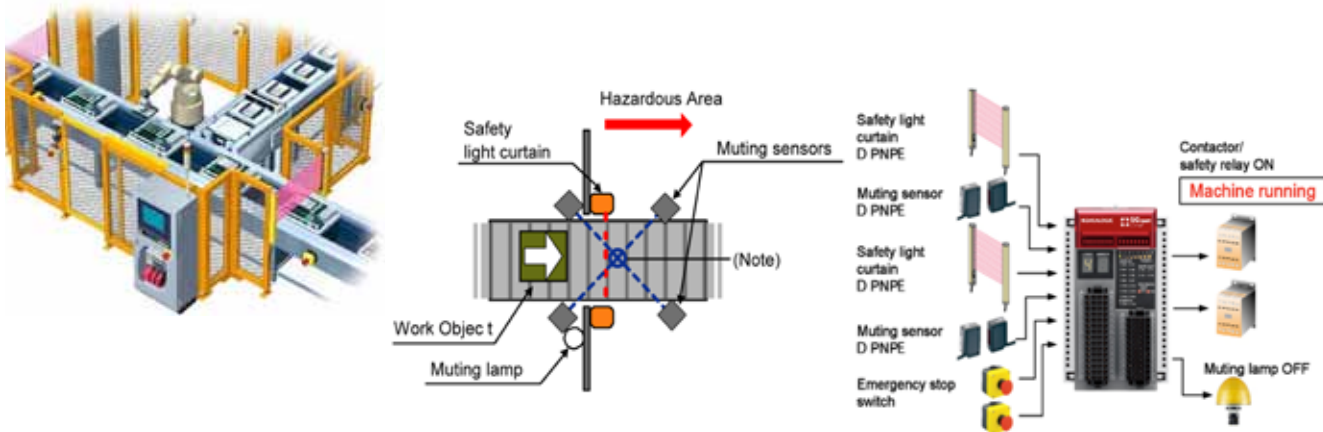

LOGIC CONFIGURATIONS

Logic 5

General purpose logic for devices for which sync time between contacts cannot be specified

The logic described is for safety protective measures applicable to production machinery, robots, and other machinery. This logic enables the connection 6 dual channel dependent inputs. Same as Logic 1, when SG-ONE is in the safe state, all of the safety inputs can receive safety input signals (the contacts of all connected safety devices are ON), safety outputs are turned ON upon input of the start input. While the safety outputs are ON, if the safety input signal to any input of the safety inputs has been turned OFF (the contacts of any the safety devices are OFF), the safety outputs are turned OFF after the preset OFF-delay time. The difference from Logic 1 is that the input monitoring error detection time in Logic 5 is infinite, so safety functions can be performed independent of the speed of opening the guard.

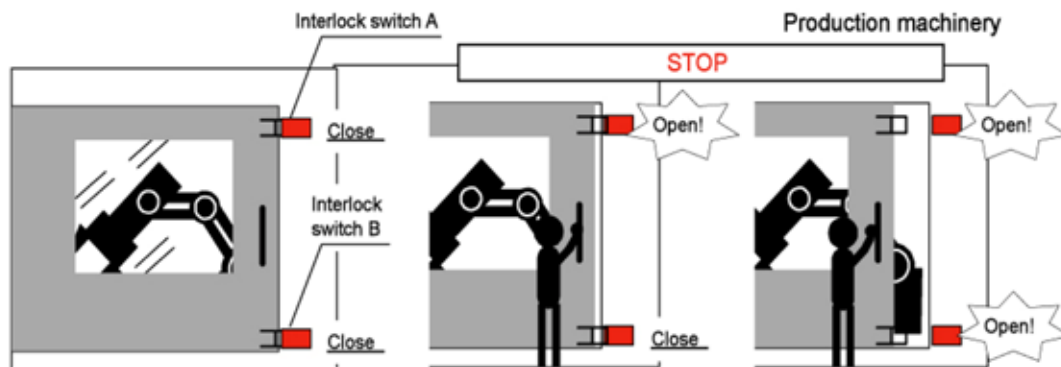
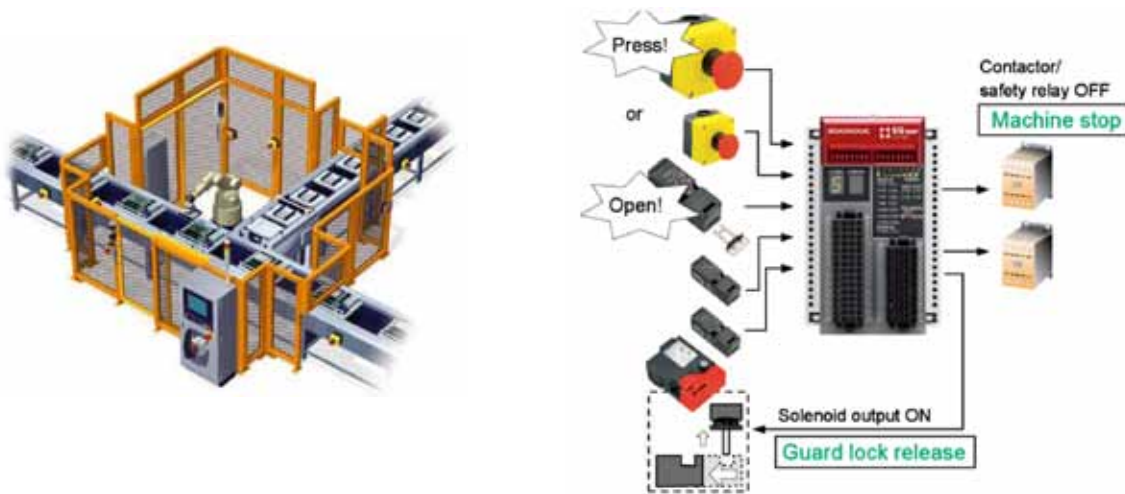

In case of Logic 1

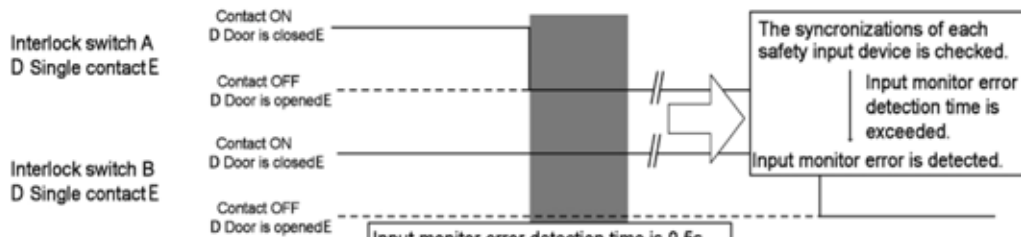

In case of Logic 5

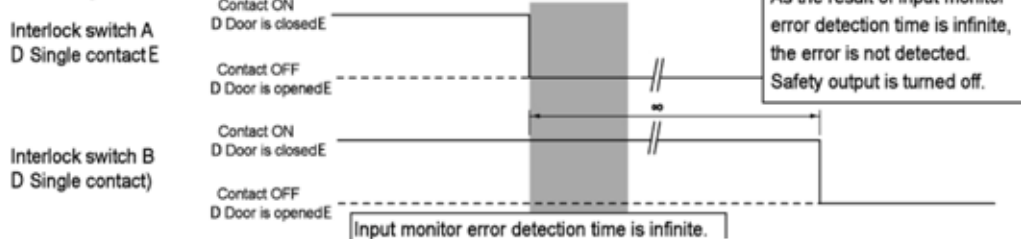

Logic 6

The logic applicable for selection of an active safety input device

For production machines, robots, and the like, a hazard is generally isolated by a usual protective door (guard); however, when performing maintenance, the machine is operated in the condition that a person is in the danger zone. For such a situation, the logic described is applicable to the mode selection between teach mode (maintenance mode) and the auto mode (operating mode). This logic enables the connection of 1 mode select input, a dual channel dependent input, and a four dual channel direct opening input.

While SG-ONE is in the teach mode, if safety inputs 2 (active only in teach mode), 5 and 6 (always active) can receive safety input signals (all contacts of the safety devices are ON), safety outputs are turned ON upon input of the start input. While the safety outputs are ON, if the safety input signal to any of the safety inputs 2, 5 or 6 have been turned OFF (the contact of any safety device is OFF), the safety outputs are turned OFF after the preset OFF-delay time has elapsed.

When SG-ONE is in auto mode, if safety inputs 3, 4 (active only in auto mode) 5, and 6 (always active) can receive safety input signals (all contacts of the safety devices are ON), safety outputs are turned ON upon input of the start input. While the safety outputs are ON, if the safety input signal to any input of the safety input 3, 4, 5 or 6 have been turned OFF (the contact of any safety device is OFF), the safety outputs are turned OFF after the preset OFF-delay time has elapsed.



Auto mode (Operating mode) - Machine running



Machine stop (Safe state)

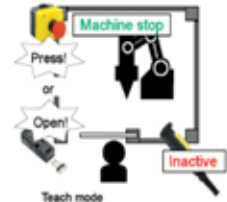

Teach mode (operating mode) - Machine running



Machine stop (Safe state)



LOGIC CONFIGURATIONS

**Logic
7**

Partial stop 1 logic for various machines

The logic described is for safety protective measures of the equipment which has 2 separate devices that are stopped by safety outputs independently, such as semiconductor manufacturing machines, and food packaging machinery. When the 2 devices can not be stopped at the same time or it is not necessary, the 2 safety outputs can be controlled separately. This logic enables the connection 5 dual channel direct opening inputs. When in the state in which safety input 1 corresponds to safety output 1 and 2, and safety input 2 and 3 corresponds to safety output 1 can receive safety input signals (the contacts of the connected safety devices are ON), safety output 1 is turned ON upon input of a start input. When in the state in which the safety input corresponds to safety output 1 and 2, and safety input 4 and 5 corresponds to safety output 2 can receive safety input signals, safety output 2 is turned ON upon input of a start input. While safety output 1 and 2 are ON, if an input signal of safety input 1 has been shut OFF (the contact of the safety device is OFF), safety outputs 1 and 2 are turned OFF after a preset OFF-delay time. If a safety input signal to safety inputs 2 or 3 is turned OFF, then safety output 1 is turned OFF. If the safety input signal to safety input 4 or 5 is turned OFF, then safety output 2 is turned OFF.

Note: Refer to "Logic circuit" for the details of safety inputs 1, 2, 3, 4, 5 and safety output 1, 2.

Machine running

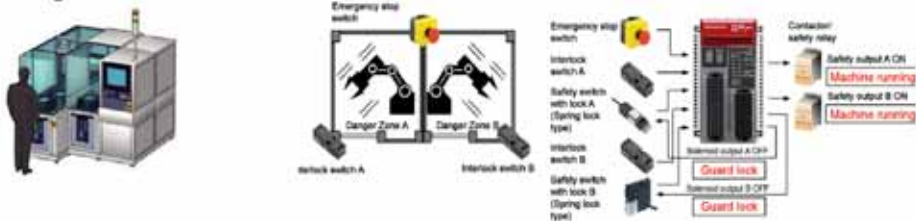

Machine stop <danger zone A>

Movable guard A is opened.

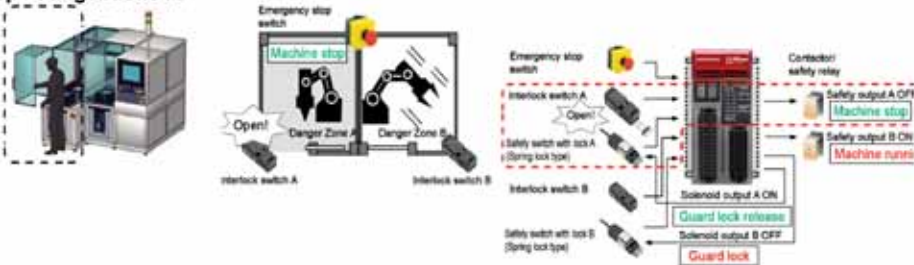

Machine stop <danger zone B>

Movable guard B is opened.

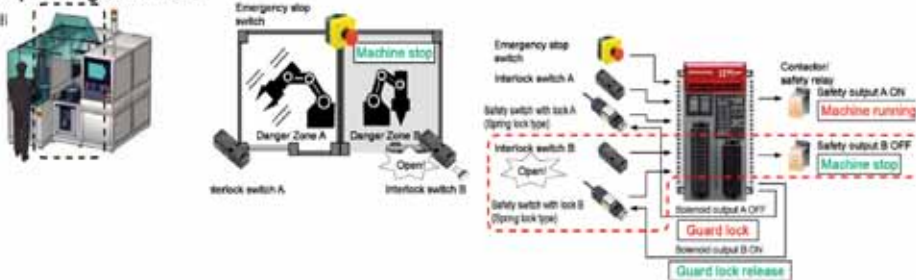

Whole machine stops <danger zone A & B>

Emergency stop switch is pressed.

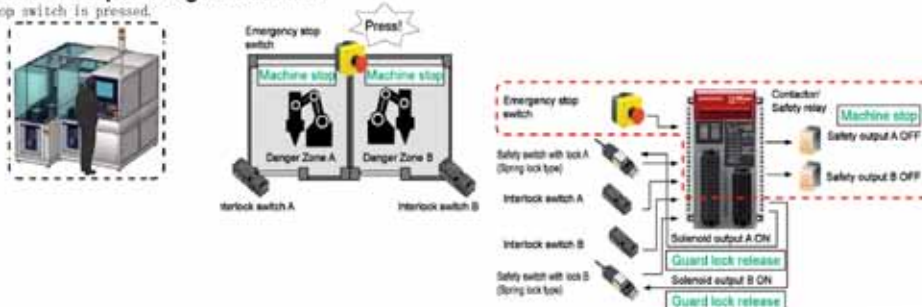

LOGIC CONFIGURATIONS

Logic 8

Partial stop 2 logic for various machinery

The logic described is for safety protective measures of equipment which has 2 separate devices that are stopped by safety outputs independently, such as semiconductor manufacturing machines, and food packaging machinery. When 2 devices can not be stopped at the same time or it is not necessary, that 2 safety outputs can be controlled separately. This logic enables the connection 5 dual channel direct opening inputs.

When in the state in which safety inputs 1, 2, and 3 correspond to safety outputs 1 and 2 can receive the safety input signals (the contacts of the connected safety devices are ON), the safety output 1 is turned ON upon input of the start input. When in the state in which the all of the safety inputs 1 to 5 can receive safety input signals, safety outputs 1 and 2 are turned ON upon input of the start input.

The safety outputs 1 and 2 are ON, if the input signal to safety inputs 1, 2, or 3 is turned OFF (the contact of the safety device is OFF), safety outputs 1 and 2 are turned OFF after the preset OFF-delay time.

If the safety input signal to safety inputs 4 or 5 corresponding to safety output 2 is turned OFF, safety output 2 is turned OFF.

Note: Refer to "Logic circuit" for the details of safety inputs 1, 2, 3, 4, 5 and safety outputs 1, 2.

Machine stop <danger zone B>

Movable guard B is opened.

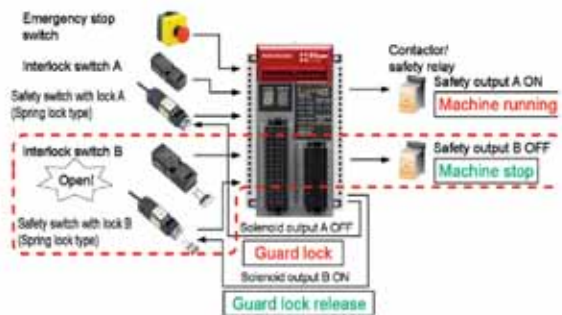

Whole machine stops <danger zone A □ B>

Emergency stop switch is pressed or movable guard A is opened.

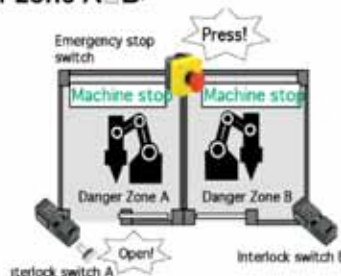

MODEL SELECTION AND ORDER INFORMATION

MODEL	DESCRIPTION	ORDER N°
SG-ONE-T4-8C	CONFIGURABLE CAT. 4 SAFETY CONTROL UNIT	957051020



The company endeavours to continuously improve and renew its products; for this reason the technical data and contents of this catalogue may undergo variations without prior notice. For correct installation and use, the company can guarantee only the data indicated in the instruction manual supplied with the products.