

## SG IP69K SERIES

The **SG-IP69K** accessory, is a PMMA acrylic tube used to protect and seal the safety light curtains of **SG2, SG4** and **SG BODY COMPACT** series. Thanks to SG-IP69K accessory the IP protection of the safety light curtain is increased from **IP65 to IP67, IP68 and IP69K**.

The **Gore-Tex membrane** on the caps prevents water or dirt entering as well as internal condensation. The connection cable for the light curtain is protected and kept in its place by a M16 metric chock that prevents the entry of water or dirt.



# SENSORS

## FEATURES

- Guarantees IP67, IP68 and IP69K mechanical protection
- Acrylic tubular PMMA housing
- Available for all models of the different heights of the SG2, SG4 (150 – 1800 mm) and SG BODY Compact (2, 3 and 4 beams) series
- Does not compromise the performance of the light curtain in terms of alignment
- Do not change the EAA value

## APPLICATIONS

The SG-IP69K accessory is particularly used where high levels of humidity and temperature are present and machines or equipments are frequently washed with hot water (up to 80°C) at high pressure (up to 100 bar s) and / or cleaned with detergents. SG-IP69K is particularly suitable for FOOD industry applications:

- beverage production
- meat slaughter
- sausage production
- milk / cheese industry



Two stainless steel rotating brackets, to be mounted on the product caps, are supplied and guarantee quick and easy installation. The PMMA Acrylic tube, thanks to its mechanical characteristics, **avoids the deterioration of the light curtain's Effective Aperture Angle (EAA) guaranteeing the alignment ease.**

## DIMENSIONS

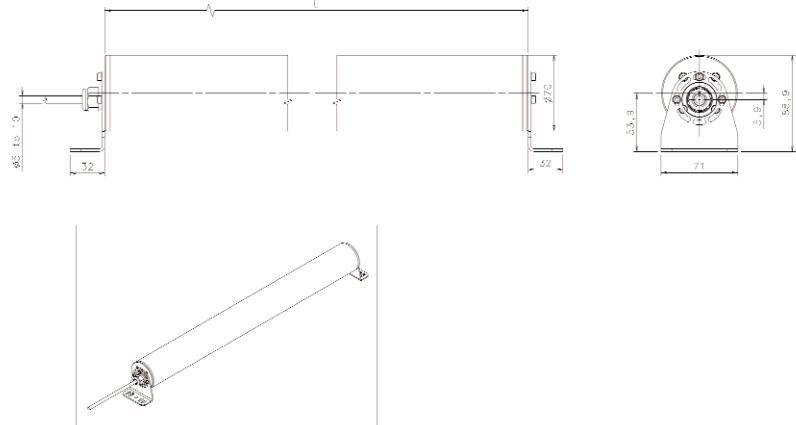

MODEL	L (mm)
SG-IP69K 150	373,5
SG-IP69K 300	520,7
SG-IP69K 450	670,8
SG-IP69K 600	820,7
SG-IP69K 750	970,8
SG-IP69K 900	1120,7
SG-IP69K 1050	1270,7
SG-IP69K 1200	1420,8
SG-IP69K 1350	1570,7
SG-IP69K 1500	1720,8
SG-IP69K 1650	1870,8
SG-IP69K 1800	2020,8

mm

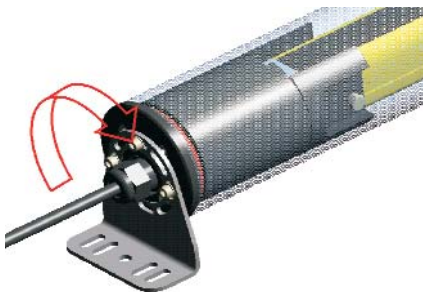

## FIXING BRACKET

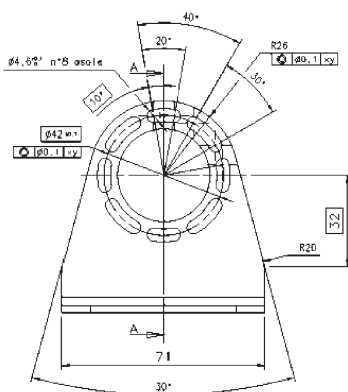

## TECHNICAL DATA

MECHANICAL DATA	
Housing material:	Weep-Spin-Dry Policril PMMA
Depth:	4mm
Protection degree:	IP67, IP68 and IP69K*
OPTICAL DATA	
Operative distance / reduction factor:	10% for each unit*
EAA aberration (Effective Aperture Angle):	None

\* technical data refers to the safety light curtains installed inside the accessory

**CHEMICAL RESISTANCE TABLE**

INORGANIC ACID	CONCENTRATION	RESISTANCE
Boric acid		FR
Hydrochloric acid	< 40%	FR
Chromic acid	< 40%	FR
Chlorosulfuric acid		FR
Hydrogen fluoride	< 40%	MR
Phosphoric acid	< 30%	FR
Nitric Acid	< 20%	MR
Concentrate nitric acid		NR
Sulfuric acid	< 40%	FR
Sulfuric acid	< 80%	MR
Sulfuric acid	1%	FR
Acid for accumulators		FR
<b>ALKALINE ACID</b>		
Ammoniacal		FR
Barium hydrate, saturate solution		FR
Potassic Carbonate, saturate solution		MR
Soda Ash, saturate solution		FR
Milk of Lime		FR
Caustic Potassium, whatever concentration		MR
sodium hydroxide, whatever concentration		FR
<b>SOSTANZE INORGANICHE</b>		
Chlorine water		FR
hydrogen peroxide 40 volums		FR
hydrogen peroxide 120 volums		NR
Aluminium Chloride		FR
Aluminium fluoride		MR
Aluminium oxalate		FR
Aluminium sulphate		FR
Potassium alum		FR
Ammonium carbonate		FR
Ammonium chloride		FR
Ammonium fluoride		FR
Ammonium nitrate		FR
Ammonium sulphate		FR
Argent nitrate		FR
Barium Chloride		FR
Barium sulphate		FR
Calcium Chloride		FR
Calcium hypochlorite		MR
Liquid Chlorine		NR
Sulfuryl chloride		NR
Ferric chloride (ico)		FR
Ferric chloride (oso)		FR
Ferric sulphate (oso)		FR
Magnesium Chloride		FR
Magnesium Sulphate		FR

**LEGGEND**

FR = Full resistance  
 MR = Medium resistance  
 NR = No resistance

## CHEMICAL RESISTANCE TABLE

SOLVENT E ORGANIC COMPOUNDS	CONCENTRATION	RESISTANCE
Amyl acetate		NR
Manganese(II) sulfate		FR
Mercury sulphate		MR
Nickel sulphate		FR
Potassium bicarbonate		FR
Potassium dichromate		FR
Potassium carbonate		FR
Potassium cyanide		FR
Potassium ferricyanide		FR
Niter (saltpeter)		FR
Potassium permanganate		FR
Potassium sulfite		FR
Potassium sulfate		FR
Copper(II) chloride		FR
Copper sulphate		FR
Silicon tetrachloride		NR
Sodium bisulphite		FR
Sodium cyanide		FR
Sodium chlorate		FR
Sodium Cloride		FR
Sodium fluoride		FR
Sodium phosphate		MR
Sodium hypochlorite		MR
Sodium nitrate		FR
Sodium sulphate		FR
Sodium sulphur		FR
Tin chloride (oso)		FR
Tin chloride (ico)		FR
Tin sulphate (ico)		FR
Zinc sulphate		FR
Zinc chloride		FR
Sulphur		FR

### LEGGEND

FR = Full resistance  
 MR = Medium resistance  
 NR = No resistance

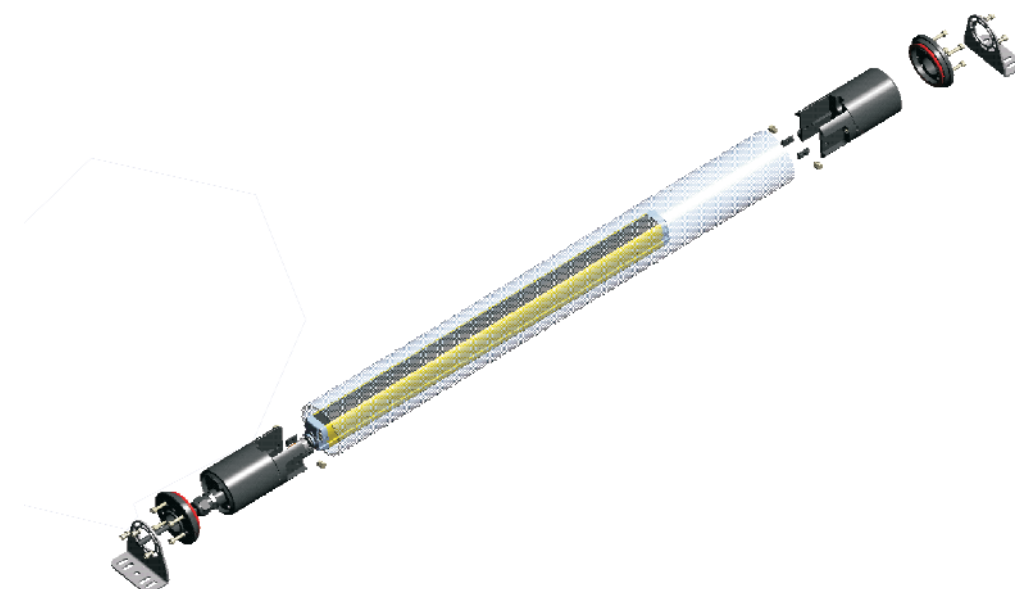

**CHEMICAL RESISTANCE TABLE**

ORGANIC ACIDS	CONCENTRATION	RESISTANCE
Concentrated acetic acid		NR
Acetyl acid	< 10%	FR
Butyric acid	< 5%	FR
Formic acid		NR
Formic acid	< 2%	FR
Lactic acid	< 10%	FR
Oxalic acid		FR
Picric acid	1% (in water)	FR
Stearic acid		FR
Tartaric acid	< 20%	FR
Thioglycolic acid	< 10%	MR
trichloroacetic acid		NR
Ethyl acetate		NR
Acetone		NR
Alcool allilico		NR
Alcool amilico		NR
n-Butanol		NR
Ethil alcohol	< 20%	FR
ethyl alcohol		NR
Isopropyl alcohol		NR
Wood alcohol		NR
1-propyl alcohol		NR
acetic aldehyde		NR
Acetic anhydride		NR
formaldehyde		FR
Aniline		NR
Benzine		MR
Benzole		NR
Ethil bromide		NR
Butirrato di etile		NR
chlorophenol		NR
chloroform		NR
Ethil chloryde		NR
Aviation gasoline		MR
cresol, methyl phenol		NR
Decalina		FR
Diacetonalcool		NR
1,4-Dioxane		NR
Ethylene bromide		NR
Bis(2-ethylhexyl) phthalate		MR
Heptane		FR
Esalina		FR
Hexane		FR
ThilChloroether		NR
Petroleum ether		FR
Phenol		FR
Ethyl ether		NR
Ftalato diamilico		NR
Ftalato dibutilico		NR
Glycerine		FR
2-etandiolo		FR
Butyl lactate		NR
methyl ethyl ketone		NR
Monobromo naftalina		FR
naphthalene		FR
pyridine		NR
propylene, methyl ethylene, propene		NR
Carbon disulfide		NR
Freon		NR
Tetrachloroethylene		NR
Carbon tetrachloride		NR
Tetrahydrofuran		NR
Tetralina		NR
Tolulo		NR

**LEGGEND**

FR = Full resistance  
 MR = Medium resistance  
 NR = No resistance

## CHEMICAL RESISTANCE TABLE

DISINFECTANTS	CONCENTRATION	RESISTANCE
Hydrogen peroxide 100 volums		FR
Turpentine		FR
trichloroethylene		NR
Tricresisolfato		NR
Trietillamina		FR
xylol		NR
<b>GAS</b>		
ammonia		FR
Carbon dioxide		FR
Sulfur trioxide		FR
Sulfur dioxide		FR
Nitrogen dioxide		FR
Gas illuminante		FR
Hydrogen sulfide		FR
Methane		FR
Carbon monoxide		FR
Oxygen		FR
Ozone		FR
Bromine vapors		MR
Chlorine vapors		MR
<b>FOODS</b>		
Vinegar		FR
Water		FR
Mineral water		FR
Anise		FR
Beer		FR
Coffee		FR
Cinnamon		FR
Chocolate		FR
Onion		FR
chamomile extract		FR
Lauro leaves		FR
Dianthus		NR
Milk of Lime		FR
Liquors		NR
Nutmeg		FR
Pepper		FR
Cider		FR
Juice		FR
wine		FR

### LEGGEND

FR = Full resistance  
 MR = Medium resistance  
 NR = No resistance

**CHEMICAL RESISTANCE TABLE**

FATS, OILS, WAX	CONCENTRATION	RESISTANCE
Refining fatty acid		FR
Floor wax		MR
Diesel oil		FR
Vegetable oils and fats		FR
Mineral oils		FR
Moneral oils and fats		FR
Transformer oil		FR
<b>DETERGENTS</b>		
Alcool	< 20%	FR
Carbolic acid		NR
DDT (dichlorodiphenyltrichloroethane)		MR
Formalia (se è formalina = Formaldehyde)		FR
Pasta di cloramina		NR
Calcium hypochlorite pulp		FR
Ethanol denaturated		NR
Soluzione cloramina	< 2%	FR
Calcium chloride solution	< 2%	FR
Mercury(II) chloride		FR
Alcool anidro		NR
Pure gasoline		NR
Sodium hypochlorite		FR
Solvent stain remover		NR
Ammonia water solution		FR

**LEGEND**

FR = Full resistance  
 MR = Medium resistance  
 NR = No resistance

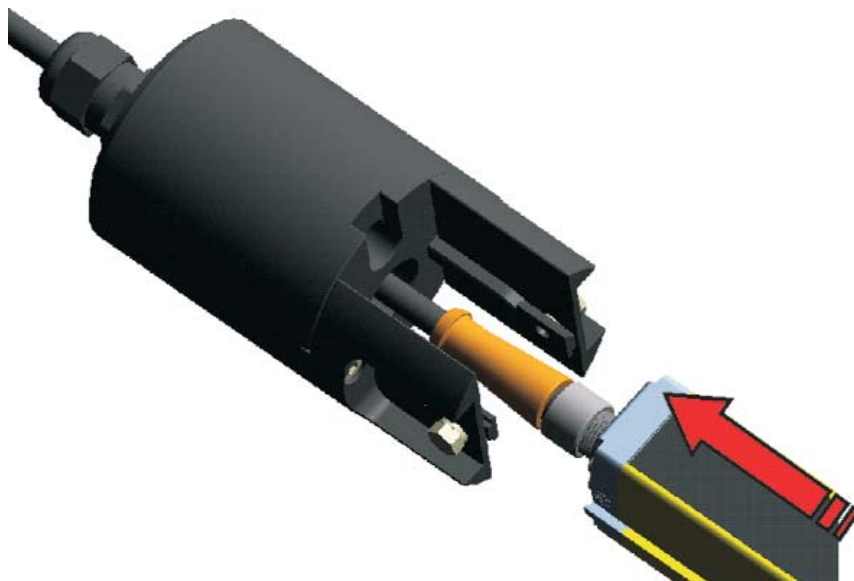

## MODELS

MODEL	DESCRIPTION	ORDER N°
SG-IP69K 150	Tubular IP69K H=150mm	95ASE1290
SG-IP69K 300	Tubular IP69K H=300mm	95ASE1300
SG-IP69K 450	Tubular IP69K H=450mm	95ASE1310
SG-IP69K 600	Tubular IP69K H=600mm	95ASE1320
SG-IP69K 750	Tubular IP69K H=750mm	95ASE1330
SG-IP69K 900	Tubular IP69K H=900mm	95ASE1340
SG-IP69K 1050	Tubular IP69K H=1050mm	95ASE1350
SG-IP69K 1200	Tubular IP69K H=1200mm	95ASE1360
SG-IP69K 1350	Tubular IP69K H=1350mm	95ASE1370
SG-IP69K 1500	Tubular IP69K H=1500mm	95ASE1380
SG-IP69K 1650	Tubular IP69K H=1650mm	95ASE1390
SG-IP69K 1800	Tubular IP69K H=1800mm	95ASE1400



The company endeavours to continuously improve and renew its products; for this reason the technical data and contents of this catalogue may undergo variations without prior notice. For correct installation and use, the company can guarantee only the data indicated in the instruction manual supplied with the products.