

S8 BGS SHINY

The NEW S8 sensor known as the SHINY has a new patented technology which means it is able to detect transparent objects using a form of laser based background suppression. Glass or clear plastic objects such as bottles, vials, packaging films, etc. can be easily detected directly even in the presence of shiny or reflective backgrounds.

This breakthrough technology offers many improvements with respect to previous systems based on polarized retro-reflex photoelectric or even ultrasonic sensors:

- No prismatic reflector: there is no need to have the clear object passing between sensor and reflector so reducing installation time and cost.
- Less mechanical constraints: the detection can be made from either the side or from the above with no need to screen or modify any metal parts of the machine.
- Highest depth of field: the clear object can move or float in any position between its background and the sensor without any need to adjust the detection threshold.



HIGHLIGHTS

- 50 to 150mm operating range with fine mechanical adjustment
- High resolution
- Bright visible red Laser light emission with 5mm spot at maximum distance
- Fast response time: 1ms with a switching frequency of 500Hz.

APPLICATIONS

Food & Pharma



Beverage & Bottling



Packaging lines



DIMENSION

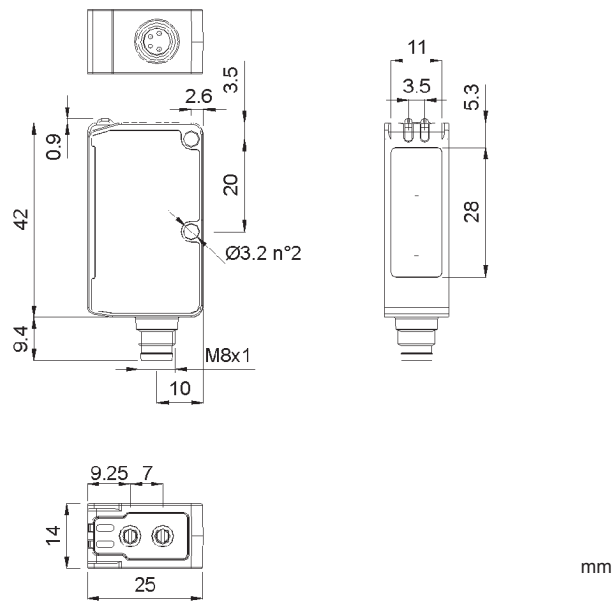

mm

SETTING

SUPPRESSION DISTANCE AND BACKGROUND ACQUISITION SETTING

The S8-PH...M53 sensor which provides background suppression for shiny objects, enables the detection of clear objects without false or multiple triggering typical of other background suppression sensors. To function correctly it is necessary to perform the Background Acquisition Setting procedure described below.

1. Start Setting and Background Acquisition

Rotate the TEACH-IN trimmer fully counter-clockwise. If the trimmer is already in the counter-clockwise position, rotate it to the clockwise position and then back to the counter-clockwise position. The N.O. Output signal (black wire) is set to OFF and the yellow LED indicates the status in the same way as a standard background suppression sensor.

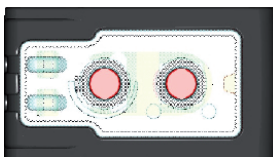

2. Background Exclusion

Position the sensor in front of the background. Rotate the DISTANCE ADJUSTMENT trimmer clockwise until the yellow LED turns ON: condition where background is detected.

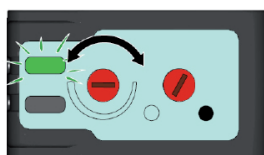
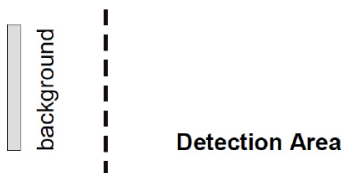

3. Background Acquisition

Rotate the TEACH-IN trimmer fully clockwise. The sensor acquires the background characteristics and is ready to detect any object that passes in the Detection Area. If the yellow LED blinks, the background acquisition procedure has failed. Rotate the TEACH-IN trimmer fully counter-clockwise and repeat the procedure from step 2.

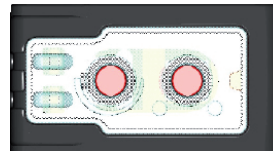

BACKGROUND AUTO-ADJUSTMENT FUNCTION

The sensor provides a background auto-adjustment function. If the background deteriorates and the received signal changes, after 1 minute the sensor automatically adjusts the background to compensate for this change therefore avoiding the need to continually acquire the background through manual setting.

CONNECTIONS

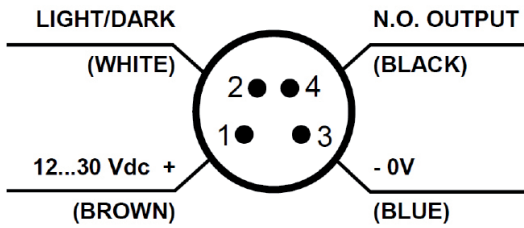

DETECTION DIAGRAM

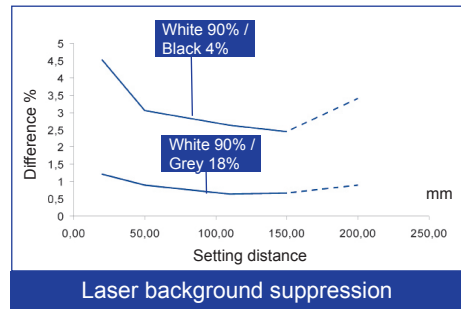

INDICATORS AND SETTINGS

S8...M53

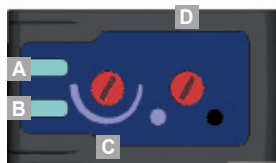

- A** Output status LED
- B** Ready LED or Power ON LED
- C** Distance adjustment trimmer
- D** Background setting trimmer

TECHNICAL DATA OF MODELS WITH LASER EMISSION

Background suppression operative distance:	50 ... 150 mm
Power supply:	12 ... 30 Vdc
Ripple:	≤ 2 Vpp
Consumption:	≤ 30 mA
Light emission:	red Laser 645...665 nm
	class II EN 60825-1
	class II CDRH21 CFR 1040.10
Spot dimension:	≤ 0.2 mm at 110 mm
Focussing point:	110 mm
Setting:	multi-turn distance adjustment trimmer monoturn trimmer background setting
Indicators:	yellow OUTPUT LED green POWER ON LED
Output type:	PNP N.O./N.C.
Output current:	≤ 100 mA
Saturation current:	≤ 2 V
Response time:	1 ms
Max. switching frequency:	500 Hz
Operating mode:	selectable dark/light by wire
Connection:	M8 4-pole connector
Mechanical protection:	IP67
Protection devices:	A, B
Housing material:	ABS
Lens material:	window in PMMA lenses in PC
Weight:	12 g max. connector version
Operating temperature::	-10 ... +55°C
Storage temperature:	-20 ... +70°C
Reference standard:	EN 60947-5-2, EN 60825-1, CDRH21 CFR 1040.10

TECHNICAL NOTES

- ¹ Average life of 50.000 h with TA = +25 °C
- ² A - reverse polarity protection
B - overload and short-circuit protection



MODEL SELECTION AND ORDER INFORMATION

MODEL	FUNCTION	CONNECTION	OUTPUT	ORDER N°
S8-PH-5-M53-PP	Background Suppression Clear Object Detection	M8	PNP	950801380

ACCESSORY SELECTION AND ORDER INFORMATION

MODEL	DESCRIPTION	ORDER N°
ST-5072	fixing bracket	95ACC1470
R4K	IP69K plastic reflector 51 x 61 mm	95A151220

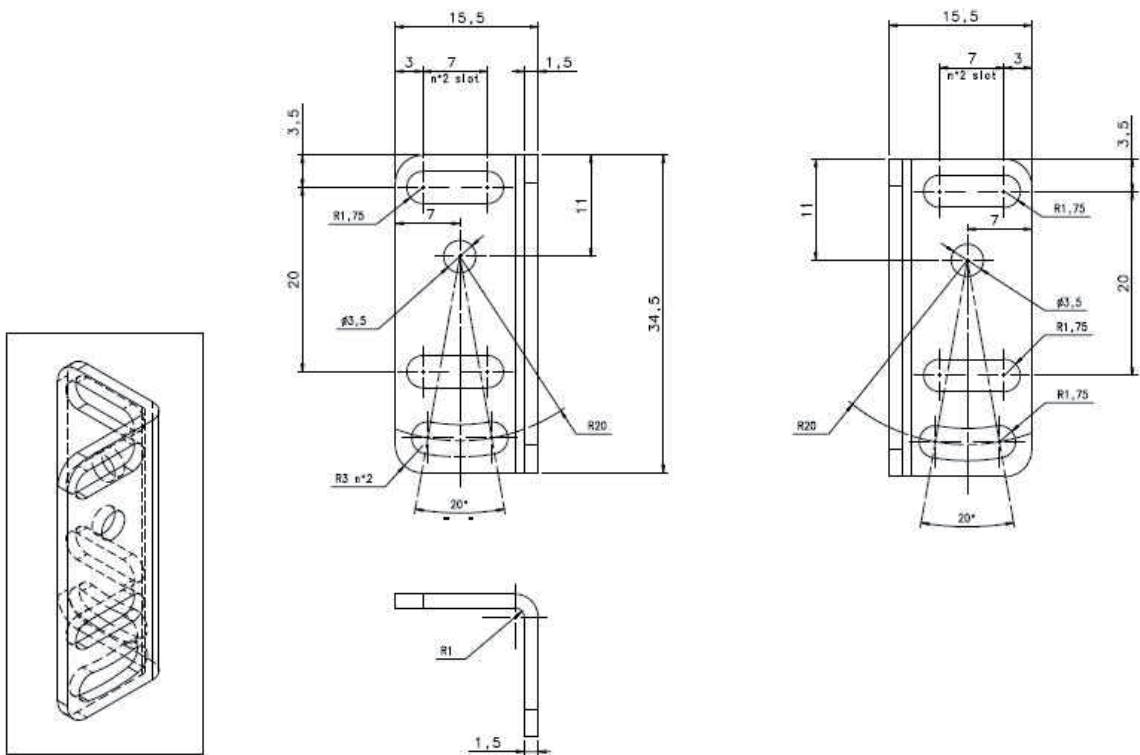

The company endeavours to continuously improve and renew its products; for this reason the technical data and contents of this catalogue may undergo variations without prior notice. For correct installation and use, the company can guarantee only the data indicated in the instruction manual supplied with the products.

Rev. 00, 06/2011