



High 12 bit resolution and 30 kHz switching speed

3 push-button setting with 4-digit display indication

All setting modes: automatic, manual or dynamic

PNP or NPN output with RS485 serial interface for data transmission

S65-W SERIES

The **S65-W** series offers, in a sturdy standard compact 50x50 mm ABS housing with IP67 mechanical protection, an advanced contrast sensor for the detection of register marks and other neutral or coloured targets.

The state-of-the-art technology with wide-spectrum white LED emission guarantees the detection of all contrasts, such as marks or objects very similar to their backgrounds or in presence of different surface treatments or workings.

The control panel presents three push-buttons for easy and immediate setting and a 4-digit display that indicates the configuration parameters and the level of received signal without the need of connecting external devices.

Different operating modes, automatic *EASYtouch™* and fine, manual and dynamic, allow extremely easy and precise object detection.

Models with only one NPN or PNP switching output are available, or with RS485 serial interface for data transmission as well as an analogue monitoring output proportional to the received light intensity. Electric connection is made by means of a standard 5 or 8-pole connector according to the model.

W CONTRAST SENSORS

Sensor setting can be made in four different modes; **EASYtouch™** with one SET push-button pressure for a quicker setting, **fine** pressing twice the SET push-button for better precision, **manual** for rapid setting correction using the +/- push-buttons and **dynamic** for the detection of moving targets.

The timing function allows to set a delay of the output activation or deactivation, to avoid the detection of temporarily rapid changes, improve interfacing with slower systems or synchronise activator activation without needing external timers.



DIMENSIONS

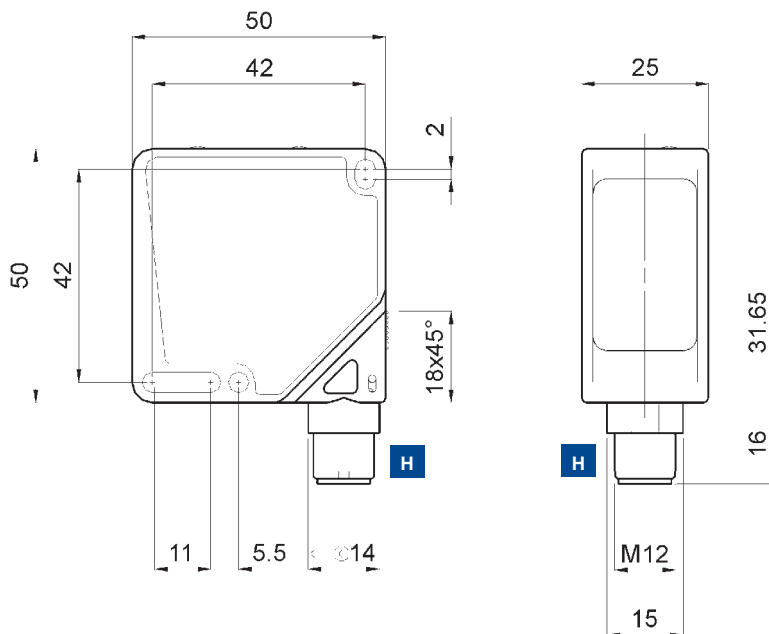

mm

INDICATORS AND SETTINGS

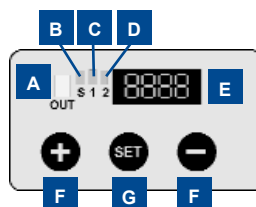

- A** Output status LED
- B** Stability LED
- C** Delay ON LED
- D** Delay OFF LED
- E** 4-digit display
- F** +/- push-buttons
- G** SET push-button
- H** M12 connector output, orientable on two positions

ACCESSORIES

For dedicated accessories refer to the **ACCESSORIES** section of this catalogue.

Refer also to **Connectors (A.03)** and **Fixing Brackets (A.04)** of the **General Catalogue**.

CONNECTIONS



M12 5-POLE CONNECTOR

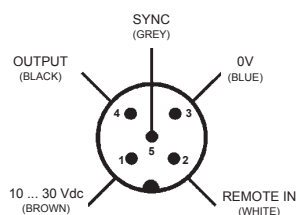

M12 8-POLE CONNECTOR

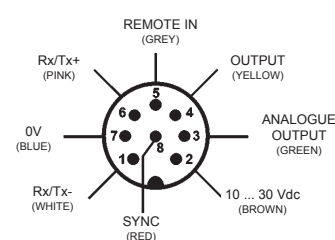

TECHNICAL DATA

		S65-PA-5-W09-NH	S65-PA-5-W09-NHZ	S65-PA-5-W09-PH	S65-PA-5-W09-PHZ
Operating distance:	12 ... 20 mm	●	●	●	●
Depth of field:	± 2 mm	●	●	●	●
Power supply:	10 ... 30 Vdc ¹	●	●	●	●
Ripple:	≤ 2 Vpp	●	●	●	●
Consumption:	50 mA max. at 24 Vdc	●	●	●	●
Light emission:	white LED 400 - 700 nm ²	●	●	●	●
Spot dimension:	3x1 mm rectangular at 19 mm	●	●	●	●
Setting:					
	+ push-button	●	●	●	●
	- push-button	●	●	●	●
	SET push-button	●	●	●	●
Digital resolution:	12 bit (4096 points)	●	●	●	●
Indicators:					
	4-digit display	●	●	●	●
	yellow active OUTPUT LED	●	●	●	●
	green ON/OFF stable OUTPUT LED	●	●	●	●
	green active DELAY ON LED	●	●	●	●
	green active DELAY OFF LED	●	●	●	●
Output type:					
	PNP - NO			●	●
	NPN - NO	●	●		
Output current:	≤ 100 mA	●	●	●	●
Saturation voltage:	≤ 2 V	●	●	●	●
Response time:	16 μs	●	●	●	●
Switching frequency:	30 KHz	●	●	●	●
Timing function:	1 ... 100 ms setting	●	●	●	●
Auxiliary functions:					
	RS485 serial interface		●		●
	keyboard lock ³	●	●	●	●
	external synchronism	●	●	●	●
Connection:					
	M12 5-pole connector ⁴	●		●	
	M12 8-pole connector ⁴		●		●
Electrical protection:	class 2	●	●	●	●
Mechanical protection:	IP67	●	●	●	●
Protection devices:	A, B ⁵	●	●	●	●
Housing material:	ABS	●	●	●	●
Lens material:	glass	●	●	●	●
Weight:	60 g max.	●	●	●	●
Operating temperature:	-10 ... +55°C	●	●	●	●
Storage temperature:	-20 ... +70°C	●	●	●	●
Reference standard:	EN 60947-5-2	●	●	●	●

SELECTION TABLE

contrast sensors			
S65-PA-5-W09-NH	954201000	NPN	
S65-PA-5-W09-NHZ	954201010	NPN	RS485
S65-PA-5-W09-PH	954201020	PNP	
S65-PA-5-W09-PHZ	954201030	PNP	RS485

TECHNICAL NOTES

- ¹ Limit values
- ² Average life of 100.000 h with $T_A = +25\text{ }^\circ\text{C}$
- ³ Is activated at powering with remote input connected to +Vdc for at least 1 sec.
- ⁴ Connector can be blocked on two positions
- ⁵ A - reverse polarity protection
B - overload and short-circuit protection



DETECTION DIAGRAMS

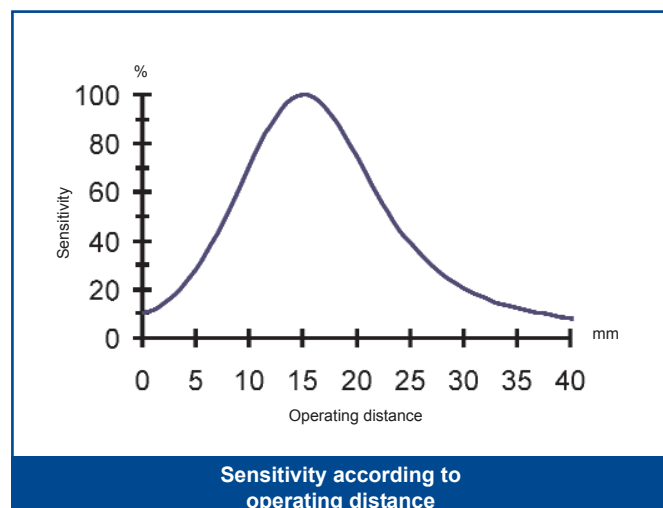

MODEL SELECTION TABLE

MODEL	CONNECTION	OUTPUT	SERIAL INTERFACE	ORDER N°
S65-PA-5-W09-NH	M12 5-pole connector	NPN	No	954201000
S65-PA-5-W09-NHZ	M12 8-pole connector	NPN	RS485	954201010
S65-PA-5-W09-PH	M12 5-pole connector	PNP	No	954201020
S65-PA-5-W09-PHZ	M12 8-pole connector	PNP	RS485	954201030

ACCESSORIES

DIMENSIONS

ST-5020

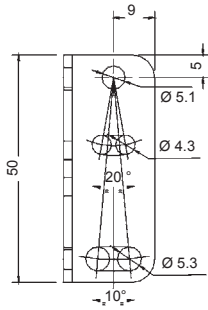
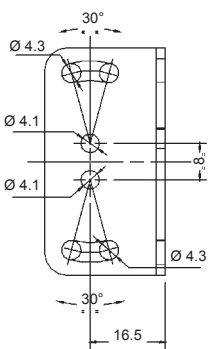
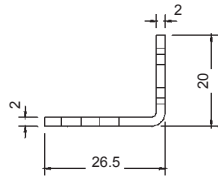

ST-5021

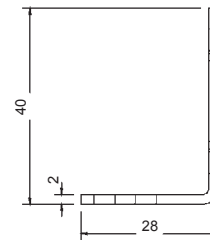
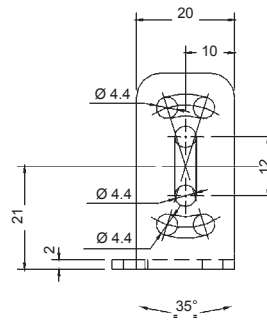
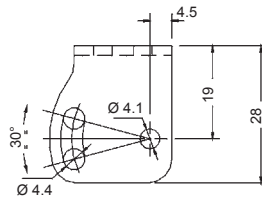

ACCESSORY SELECTION TABLE

MODEL	DESCRIPTION	ORDER N
ST-5020	50 x 27 x 20 mm fixing bracket	95ACC5330
ST-5021	20 x 40 x 28 mm fixing bracket	95ACC5340
CS-A1-03-G-03	M12 5-pole conn. with 3 m unshielded cable	95ACC2110
CS-A1-03-G-05	M12 5-pole conn. with 5 m unshielded cable	95ACC2120
CS-A1-03-G-10	M12 5-pole conn. with 10 m unshielded cable	95ACC2140
CS-A1-06-B-03	M12 8-pole conn. with 3 m unshielded cable	95ACC2230
CS-A1-06-B-05	M12 8-pole conn. with 5 m unshielded cable	95ACC2240
CS-A1-06-B-10	M12 8-pole conn. with 10 m unshielded cable	95ACC2250

Refer also to **Accessories for Sensors**

Distributed by:

HEADQUARTERS

DATASENSOR SpA
 via Lavino, 265 - 40050 Monte San Pietro, BO - Italy
 Tel. +39 051/6765611 • Fax +39 051/6759324
www.datasensor.com • e-mail info@datasensor.com

Datasensor SpA endeavours to continuously improve and renew its products; for this reason the technical data and contents of this catalogue may undergo variations without prior notice. For correct installation and use Datasensor SpA can guarantee only the data indicated in the instruction manual supplied with the products.